

clever

T A P S & S H O W E R S

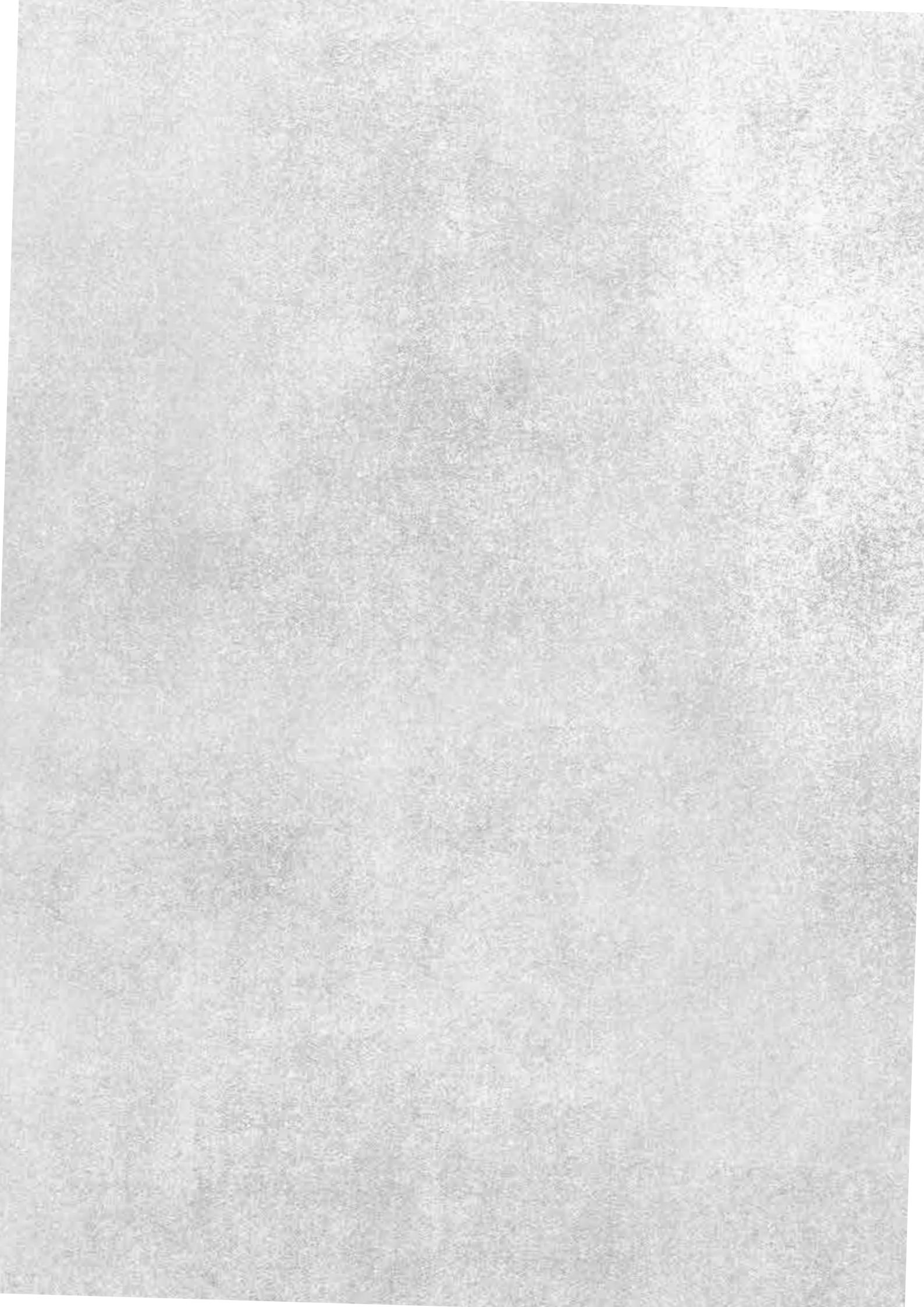

bath&kitchen
COLLECTION
2024



clever

T A P S & S H O W E R S

At STH Westco, we reaffirm our commitment in the fight against climate change.



En Standard Hidráulica reafirmamos nuestro compromiso en la lucha contra el cambio climático

Standard Hidráulica réaffirme son engagement dans la lutte contre le changement climatique.

Clever taps was launched in 1998 by Standard Hidraulica, company founded in 1975, well known as one of the most important taps, mixers and showers manufacturers in Spain. Our company's philosophy is based in quality, service, technology investigation, exquisite design and environmental respect.

In 2019 STH Group was founded, International Industrial Group consisting on Standard Hidraulica (Montcada i Reixac - Barcelona and Getafe - Madrid) and STH Westco (Leigh - Manchester UK).

In 2021 STH Group joined up two new companies; STH Southern Africa (South Africa) based in Johannesburg, Port Elizabeth and Cape Town and STH Hellas based in Athens (Greece).

These incorporations will highly contribute our Group to reinforce our experience in logistic and commercial area.

Grifería Clever nace en 1998 de Standard Hidráulica, empresa fundada en Barcelona en 1975 y reconocida como uno de los principales fabricantes de grifería y accesorios para cocina y baño en España. Con una filosofía basada en la calidad, el servicio, la cuidada atención al cliente, la constante investigación tecnológica y el respeto al medio ambiente.

En 2019, se constituye el Grupo STH (Grupo industrial internacional) formado por Standard Hidráulica (Montcada i Reixac, BCN y Getafe, MAD) y STH Westco (Leigh, Manchester, UK).

Y en 2021 el Grupo STH incorpora dos nuevas empresas; STH Southern Africa (Sudáfrica) con base en Johannesburgo, Port Elizabeth y Ciudad del Cabo y STH Hellas con base en Atenas (Grecia). Con estas integraciones se contribuye enormemente a reforzar a nuestro grupo industrial con amplia experiencia en el área logística y comercial.

Clever est né en 1998 au sein de Standard Hidráulica, une entreprise fondée à Barcelone en 1975 et est reconnu comme l'un des principaux fabricants de robinetterie et d'accessoires pour la cuisine et la salle de bains en Espagne. Notre philosophie d'entreprise est basée sur la qualité, le service, le suivi attentif de notre clientèle, la recherche continue et le respect de l'environnement.

En 2019, le groupe STH GROUP, composé de Standard Hidráulica (Montcada i Reixac, BCN et Getafe, MAD) et STH Westco (Leigh, Manchester, UK) est fondé.

Et en 2021 le groupe STH incorpore deux nouvelles entreprises, STH Southern Africa (Afrique du Sud) avec des installations à Johannesburg, Port Elizabeth et Le Cap, et STH Hellas, basé à Athènes (Grèce).

Ces nouvelles incorporations contribuent à renforcer notre groupe industriel avec une ample expérience dans les domaines logistique et commercial.

OUR PILLARS: INTEGRAL SOLUTIONS SINCE 1975

Nuestros pilares: Soluciones integrales desde 1975

Nos domaines d'expertise : Des solutions intégrales depuis 1975

STH solutions are efficiently integrated into the heart of buildings and distribution networks having a fundamental contribution into the optimal operation of the facilities. The company's philosophy is based on quality, service, investment, competitiveness and innovation.

Las soluciones de STH se integran eficientemente en el corazón de los edificios y en las redes de distribución, y son fáciles de especificar e instalar, teniendo una contribución fundamental en el óptimo funcionamiento de las instalaciones. La filosofía de la compañía está basada en la calidad, el servicio, la inversión, la competitividad y la innovación desde su fundación en 1975.

Les solutions de STH sont présentes au coeur des édifices et des réseaux de distribution. Elles apportent toujours une contribution fondamentale au bon fonctionnement du bâtiment. La philosophie de l'entreprise est basée sur la qualité, le service, l'investissement, la compétitivité et l'innovation.



STH's goal is to be recognized as the leading company in the following strategic markets:

El objetivo de STH es ser reconocida como la empresa líder en cada uno de los mercados estratégicos siguientes:

STH a pour objectif d'être reconnue comme une entreprise leader sur les marchés stratégiques suivants:

 Taps & Showers	 Valves	 Connections	 Utilities
<p>Clever, exclusive range of taps, mixers and showers for kitchens and bathrooms.</p> <p><i>STH desarrolla una exclusiva y completa gama de grifería y accesorios para baño y cocina. Calidad, innovación, tecnología, diseño y ecoeficiencia son los sellos de distinción de la grifería marca Clever.</i></p> <p><i>Clever une gamme exclusive de robinetterie et d'accessoires pour cuisine et salle de bain.</i></p>	<p>Connection solutions for thermal and sanitary networks in buildings.</p> <p><i>Soluciones para conducciones domésticas de agua y gas y sistemas completos de tubería, accesorio y válvula.</i></p> <p><i>STH propose des systèmes complets de raccordement pour les réseaux thermiques et sanitaires dans les bâtiments.</i></p>	<p>Comfort control solutions ensure the right flow for each part of a heating, air conditioning or hot water network.</p> <p><i>Las soluciones de control de STH aseguran el flujo adecuado para cada una de las redes de calefacción, climatización y agua sanitaria.</i></p> <p><i>Les solutions de régulation de STH permettent d'apporter le bon débit au bon endroit dans les réseaux de chauffage, de climatisation ou d'eau chaude sanitaire.</i></p>	<p>Connect & control solutions for water and gas distribution networks.</p> <p><i>Soluciones de unión, distribución y control para canalizaciones de agua y gas, así como armarios de gas y arquetas de agua.</i></p> <p><i>Solutions de raccordement et de contrôle pour les réseaux de distribution d'eau et de gaz.</i></p>

OUR VALUES: WINNING WITH PEOPLE

Nuestros Valores: Las Personas, el mayor activo
Nos valeurs : Les personnes, notre meilleur atout



Be an entrepreneur
Avoir l'esprit d'entreprise

Hacemos que los sueños
se hagan realidad

Take ownership
Prendre l'initiative

Cumplimos
nuestras promesas

Go for excellence
Obtenir l'excellence

Alcanzamos límites
desafiando el statu quo

Share and learn
Partager et apprendre

Aprendemos y
avanzamos gracias al
trabajo en equipo

Act with integrity
Agir avec intégrité

Somos profesionales,
actuamos de manera
ejemplar

Culture of quality, innovation, technology, design and commitment with the environment

Cultura de calidad, innovación, tecnología, diseño y compromiso con el medio ambiente
Une culture de qualité, d'innovation, de technologie, de design et engagement avec l'environnement

At our technical engineering centers, we develop innovative solutions and products that fits with the most stringent quality and certifications. STH has the ISO9001, ISO 14001 and the CARBON FOOTPRINT calculation stamp which certifies the commitment with the environment, minimizing environmental impacts and supporting the best resources management.

En nuestros centros técnicos de ingeniería, utilizando herramientas de vanguardia, desarrollamos innovadoras soluciones y familias de productos que cumplen con los más exigentes requisitos de calidad y estándares de certificación. En línea con este enfoque de calidad, STH cuenta con las certificaciones ISO9001, ISO14001 y el sello de cálculo de HUELLA DE CARBONO que acredita el compromiso con el medio ambiente, minimizando los impactos ambientales y favoreciendo la mejor gestión de los recursos.

Dans nos centres d'ingénierie technique, nous développons des solutions innovantes et des familles de produits qui répondent aux exigences de qualité et aux normes de certification les plus exigeantes. Comme conséquence de cette vision de qualité, STH dispose de la certification ISO9001, ISO14001 et le label de calcul d'EMPREINTE CARBONE qui atteste l'engagement de l'entreprise dans l'amélioration constante de ses processus en en minimisant les impacts sur l'environnement.



Our commitment
to the planet

Nuestro compromiso con el planeta
Notre engagement avec la planète

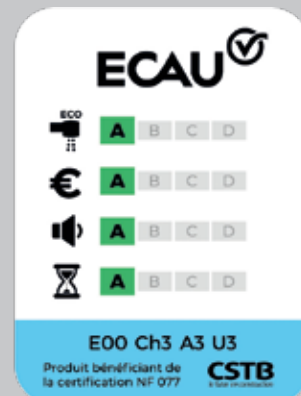
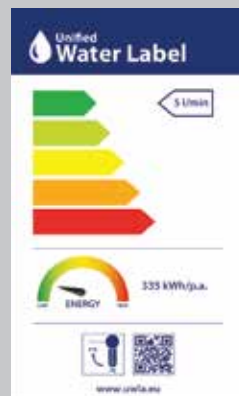

STH, YOUR PARTNER FOR THE BATHROOM SECTOR AND SHOWROOM

Availability | Disponibilidad / Disponibilité

From design to manufacturing, STH controls all stages of production and guarantees the availability of their products thanks to their logistics platforms.

Desde el diseño hasta la fabricación, Standard Hidráulica controla todas las etapas de producción y garantiza la disponibilidad de sus productos lo antes posible gracias a sus plataformas logísticas ubicadas en Barcelona y Madrid.

De la conception à la fabrication, Standard Hidráulica contrôle toutes les étapes de production et garantit la disponibilité de ses produits dans les meilleurs délais grâce aux ses plateformes logistiques.

Technical experience

Experiencia técnica/Expérience technique

The basis of STH's commitment is to inform about efficiency energy, regulations and technological innovations. |

La base del compromiso de STH es informar a las personas involucradas en el sector sobre la eficiencia energética, las regulaciones vigentes y las innovaciones tecnológicas.

Informer sur l'efficacité énergétique, sur les réglementations et les innovations est à la base de notre engagement.

Proximity | Proximidad/ Proximité

STH customer service guarantees a quick and complete answer. |

Desde la prescripción, pasando por la recepción del pedido hasta el servicio posventa; el servicio al cliente de Standard Hidráulica satisface todas las necesidades y garantiza una respuesta rápida y completa.

Le service client de STH répond à tous les besoins et garantit une réponse rapide et complète.

Support | Soporte/ Support

STH technical team supports the commercial teams throughout the territory.

El equipo técnico de STH responde todas las preguntas específicas, propuestas por los profesionales y da apoyo a los equipos comerciales presentes en todo el territorio.

Le support technique de STH répond à toutes les questions spécifiques, en support aux équipes commerciales présentes sur tout le territoire.

Training | Formación/ formation

STH provides technical assistance and practical trainings for the correct use and installation of our solutions. |

Los equipos especializados de STH están preparados para proporcionar asistencia y formación práctica en la correcta utilización e instalación de nuestras soluciones.

STH est préparé pour vous offrir son assistance et formation pratique pour l'installation et l'utilisation de nos solutions.



10.000
Referencias

References | Références



5.000
Clientes

Customers | Clients



50
Países

Countries | Pays



Tasa de servicio
+del **98%**

Service tax | Taux de service



+de **200**
Empleados

Employees | Employés





Standard Hidraulica Group sites and logistics platforms

Fábricas y plataformas logísticas de Standard Hidraulica Group

Usines et plateformes logistiques de Standard Hidráulica Group

- 1 - Montcada i Reixac (Barcelona), ES
- 2 - Getafe (Madrid), ES
- 3 - Leigh (Manchester), UK
- 4 - Atenas (Grecia), GR
- 5 - Johannesburg (Sudáfrica), ZAF
- 6 - Port Elizabeth (Sudáfrica), ZAF
- 7 - Ciudad del Cabo (Sudáfrica), ZAF



Standard Hidraulica Group distribution

Estructura comercial de Standard Hidraulica Group

Structure commerciale de Standard Hidraulica Group

- 1 - España (2)
- 2 - Ireland
- 3 - Francia
- 4 - UK
- 5 - Portugal
- 6 - Andorra
- 7 - Grecia
- 8 - Sudáfrica (3)
- 9- Benelux

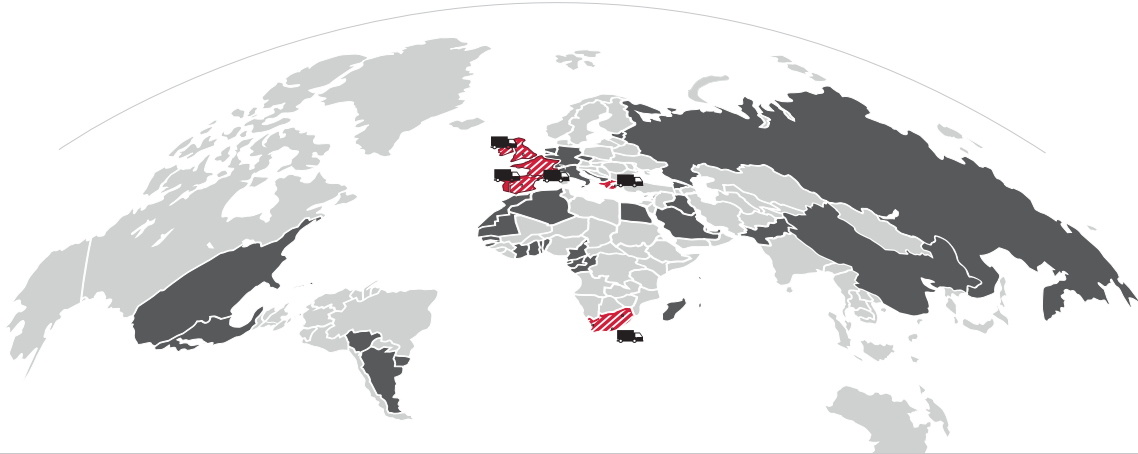

A multipurpose site for the assembling and design of plumbing & heating products, taps, mixers and showers

Plantas especializadas en el diseño y montaje de productos de fontanería y calefacción, y grifería para baño y cocina:

Une installation spécialisée dans la conception et l'assemblage de produits pour la plomberie, le chauffage et la robinetterie sanitaire.



Montcada i Reixac (Barcelona, ES)

Superficie 12.500 m2
Facilities / Installations



Leigh (Manchester, UK)

Superficie 15.000 m2
Facilities / Installations



Hellas (Grecia, GR)

Superficie 2.500 m2
Facilities / Installations



Sudáfrica (Johannesburg)

Superficie 2.400 m2
Facilities / Installations



Sudáfrica (Port Elizabeth)

Superficie 220 m2
Facilities / Installations



Sudáfrica (Ciudad del Cabo)

Superficie 300 m2
Facilities / Installations

Planta especializada en productos para redes de distribución de gas y agua:

Specialized site in distribution networks products for gas and water.

Une structure spécialisée dans les réseaux de distribution de gaz et d'eau.

Getafe (Madrid, ES)

Superficie 6.500 m2
Facilities / Installations



EFFICIENT PRODUCTS AND SOLUTIONS TO IMPROVE SUSTAINABILITY AND WELL-BEING IN HOMES

Productos y soluciones eficientes para mejorar la sostenibilidad y bienestar en las viviendas

Des produits et des solutions efficaces pour améliorer la durabilité et le bien-être dans le logement

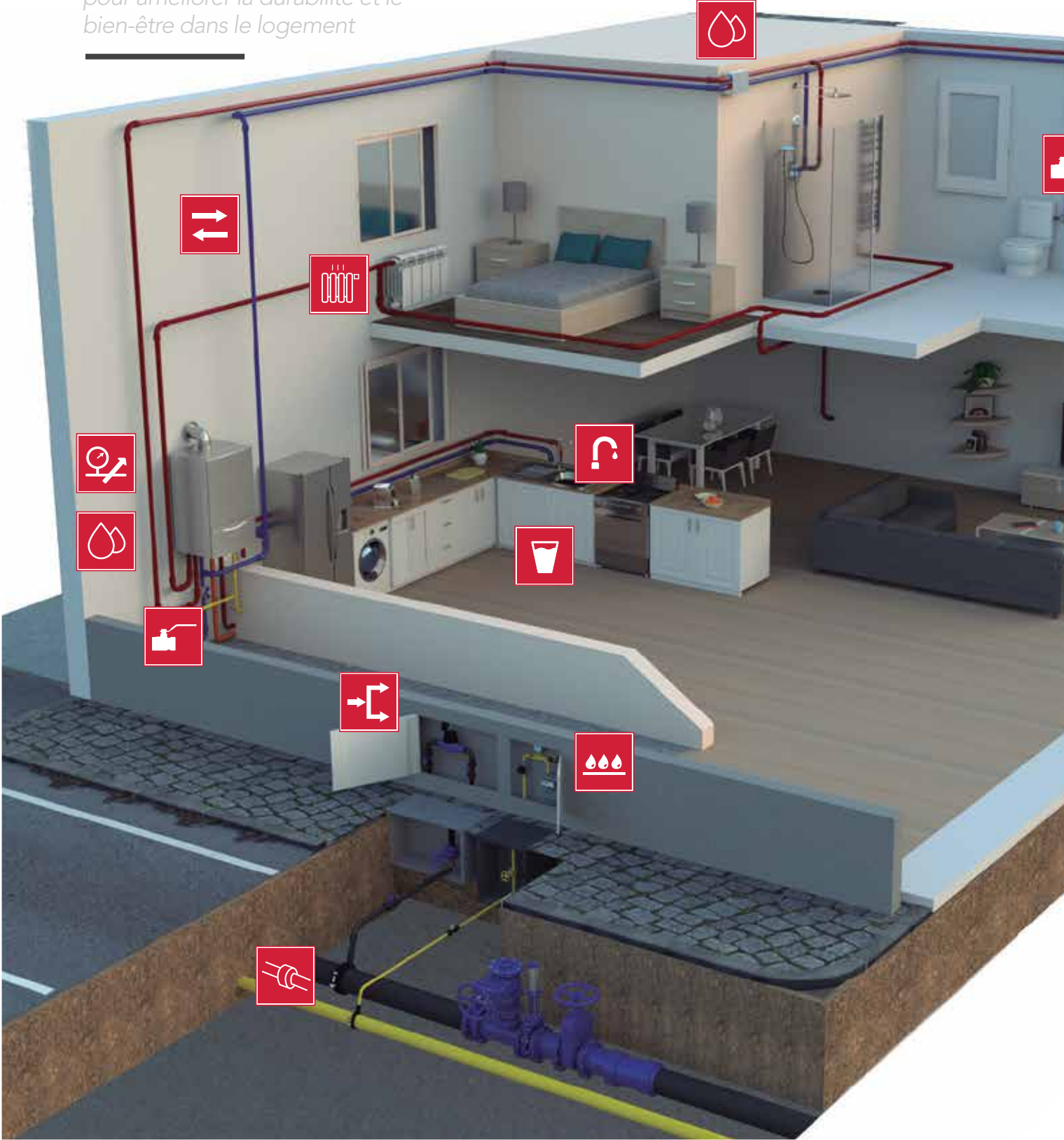

For the professionals, the objective is to offer the best product that suits the needs of the building project, optimizing the performance to the maximum.

STH's solutions for thermal and sanitary installations operate in the buildings heart (from public networks to inside the residences). Sometimes they are invisible, but always make a sustainable and fundamental contribution to the building functioning. Standard Hidráulica's environmental vision declares the intention of STH Group to guarantee energy efficiency and sustainability.

STH has been working together with different partners within the building sector, water and gas companies.. for many years. Accompanying customers and partners to help them to reach their targets to fulfill the projects and guarantee the mutual value creation.



Para los profesionales de la fontanería y la calefacción, el objetivo es ofrecer el producto que mejor se adapta a las necesidades del proyecto, para implementarlo en todo el edificio optimizando al máximo su rendimiento.

Las soluciones de STH para instalaciones térmicas y sanitarias operan en el corazón de los edificios (desde las redes públicas hasta el interior de la residencia). A veces son invisibles, pero siempre hacen una contribución sostenible y fundamental en la forma en la que

La visión ambiental de Standard Hidráulica declara la intención del Grupo STH de garantizar la eficiencia energética y la sostenibilidad.

STH ha estado trabajando junto a los diferentes actores dentro del sector de la construcción y empresas de agua y gas durante muchos años, acompañando a clientes y socios para ayudarlos a cumplir con sus proyectos y garantizando la creación de valor mutuo.

Pour les professionnels de la plomberie et du chauffage, l'objectif est de proposer le produit qui correspond le mieux aux besoins du projet pour l'installer dans tout le bâtiment en optimisant au maximum son rendement.

Les solutions de STH pour les installations thermiques et sanitaires sont présentes au cœur des édifices et des réseaux de distribution. Elles sont parfois invisibles, mais elles apportent toujours une contribution fondamentale au bon fonctionnement du bâtiment.

La vision environnementale de Standard Hidráulica démontre l'intention du Groupe STH de garantir l'efficacité énergétique et la durabilité.

STH a travaillé durant de nombreuses années en collaboration avec les différents acteurs du secteur de la construction et les entreprises de distribution d'eau et de gaz, en accompagnant ses clients et ses associés pour les aider à réaliser leurs projets et à garantir la création de valeurs communes.



Regulación y control en sistemas de agua fría y caliente
Control solutions for cold and hot water
Régulation et contrôle dans les systèmes d'eau chaude et froide



Válvulas, sistemas y conexiones
Valves, systems and connections
Vannes, systèmes et connexions



Válvulas y cabezales termostáticos para radiadores de agua caliente
Thermostatic heads and valves for radiators / Vannes et têtes thermostatique pour radiateurs d'eau chaude



Red de canalizaciones de agua y gas
Distribution networks of water and gas
Réseau de canalisations d'eau et de gaz



Armarios, válvulas y sistemas de gas
Cabinets, valves for gas systems / Armoires, vannes et systèmes de gas



Grifería para baño y cocina
Taps, mixers and showers for kitchen and bathroom
Robinetterie pour salle de bain et cuisine



Grifería y equipos para el tratamiento del agua
Taps and equipment for water quality
Robinets et équipements pour la qualité de l'eau



iKansas, sistema de cierre doméstico registrable 1 y 2 vías
iKansas, hidden domestic system, 1 and 2 ways
iKansas, système de robinets d'arrêt cachés, 1 et 2 voies



Válvulas de equilibrado estáticas y dinámicas. Filtros magnéticos
Static and dynamic balancing valves. Magnetic filters / Vannes d'équilibrage statiques et dynamiques. Filtres magnétiques



Sistemas de tubería, accesorios y válvulas para multicapa,
PE-X y PB / Pipes, fittings and valves for multilayer, PE-X and PB systems
Systèmes de tubes, raccords et vannes pour multicouche, PE-X et PB dans les réseaux de chauffage et sanitaire

*Ejemplo de vivienda con todas las soluciones y productos de Standard Hidráulica instaladas de forma sostenible y eficiente.

*STH products and solutions efficiently installed in a building.
Exemple de logement avec tous les produits et solutions de Standard Hidráulica installés de façon durable et efficace.

THE EXCELLENCE IN THE MANUFACTURING PROCESS

La excelencia en el proceso de fabricacion

L'excellence dans le processus de fabrication

Every design,
an emotion

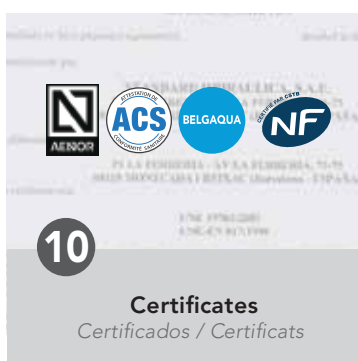
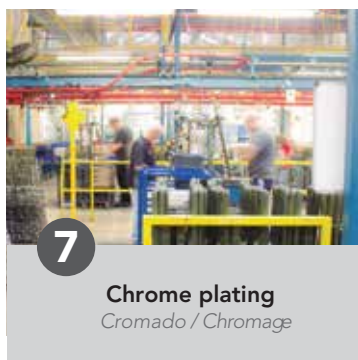
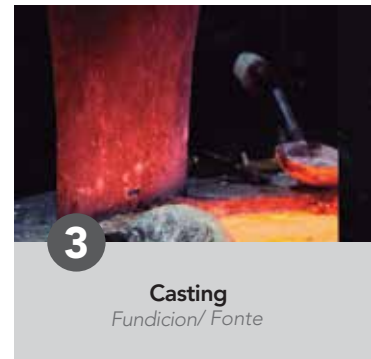
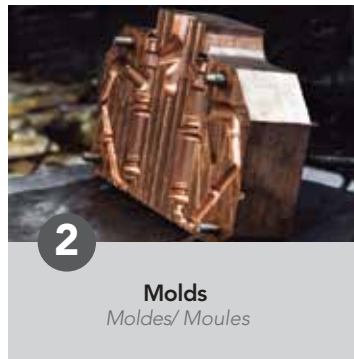

As part of our environmental commitment to reduce water usage many of our platinum level products are now fitted with a Neoperl PCA Dual Core aerator.

This allows for early aeration at lower pressure giving users a full and pleasant water stream whilst limiting the flow at higher pressure to reducing water usage without reducing performance.

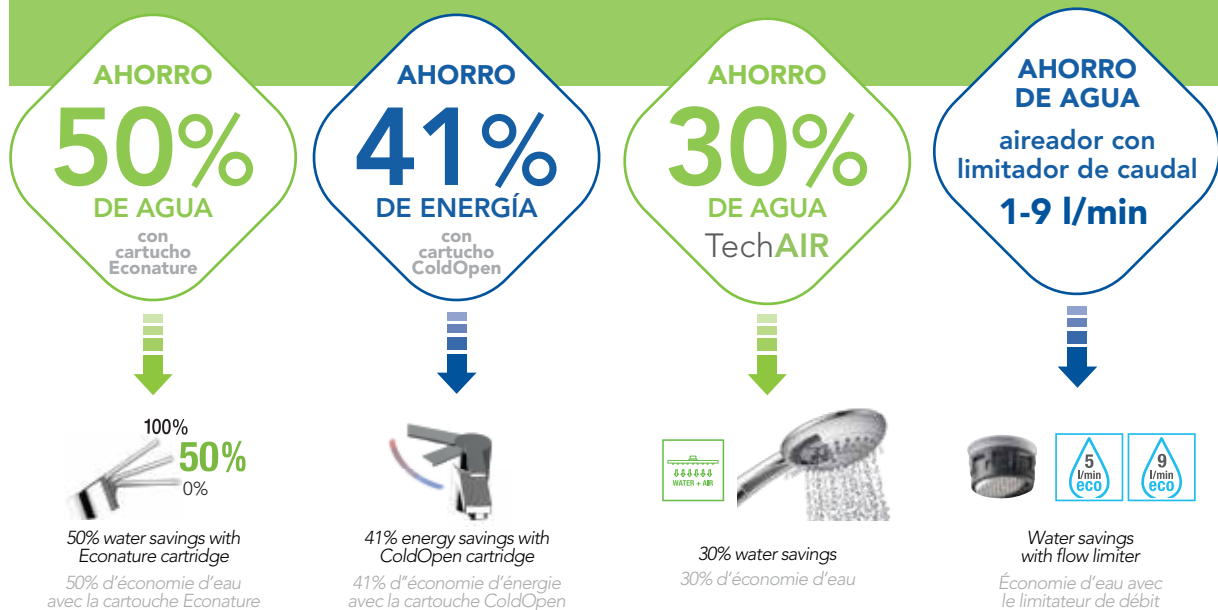

BREEAM®

The Building Research Establishment (BRE) is the company that manages it. Founded in 1921, it was the first research-oriented organization in the building sector in the world. It currently conducts research, advice and testing for the construction sectors.

El Building Research Establishment (BRE) es la entidad que lo gestiona. Fundada en 1921, fue la primera organización orientada a la investigación en el sector de la edificación en el mundo. Actualmente lleva a cabo la investigación, asesoramiento y pruebas para los sectores de la construcción.

Le Building Research Establishment (BRE) est l'entité en charge de son évaluation. Fondée en 1921, c'est la première organisation orientée vers la recherche dans le secteur du bâtiment. Elle s'occupe actuellement de recherche, de conseil et des essais d'évaluation de la performance environnementale pour les différents secteurs de la construction.



LEED®

Spain Green Building Council is the first national non-profit association of leading companies of the construction industry working together to promote environmentally responsible, cost-effective and healthy cities and buildings.

Spain Green Building Council es la primera asociación nacional sin ánimo de lucro de empresas líderes de la industria de la construcción que trabajan juntas para promover ciudades y edificios medioambientalmente responsables, rentables y saludables.

Le Spain Green Building Council est la première association espagnole à but non lucratif d'entreprises leaders dans l'industrie qui travaillent ensemble pour promouvoir des villes et des bâtiments respectueux de l'environnement, rentables et sains.



VERDE®

GBCe is a non-profit association that brings together representatives of all actors in the building sector in order to contribute to the transformation of the market towards a sustainable building concept, consistent with the United Nations Sustainable Development Goals.

GBCe es una asociación sin ánimo de lucro que reúne a representantes de todos los agentes del sector de la edificación con el fin de contribuir a la transformación del mercado hacia una edificación más sostenible, compatible con los Objetivos de Desarrollo Sostenible de Naciones Unidas.

Le GBCe est une association à but non lucratif qui rassemble des représentants de tous les acteurs du bâtiment afin de contribuer à la transformation du marché vers un bâtiment plus durable, compatible avec les Objectifs de développement durable des Nations Unies.

SUPPORTING WATER EFFICIENCY

Apoiando la eficiencia del agua
POUR SOUTENIR UNE UTILISATION RATIONNELLE DE L'EAU



What is UWLA certification?

WHAT IS UWLA CERTIFICATION? THE UWLA LABEL, UNIFIED WATER LABEL ASSOCIATION, AIMS TO ESTABLISH THE STANDARDISED, EUROPE-WIDE ENERGY STANDARDISED ACROSS EUROPE FOR ALL WATER-USING FAUCET PRODUCTS. SO THAT THE USER CAN VISUALLY UNDERSTAND THEIR LEVEL OF ENERGY EFFICIENCY.

La etiqueta UWLA, Unified Water Label Association tiene como objetivo establecer la clasificación energética estandarizada en toda Europa de todos los productos de grifería que utilizan agua en su funcionamiento para que el usuario pueda comprender de forma visual su nivel de eficiencia energética.

Qu'est-ce que la certification UWLA ? L'Unified Water Label Association (UWLA) vise à établir un classement énergétique standardisé à travers l'Europe pour tous les produits de robinetterie consommant de l'eau, afin que le consommateur puisse comprendre visuellement leur niveau d'efficacité énergétique.

Water and energy savings

UWLA-certified taps, such as those developed at Clever Taps, are designed to limit water flow as much as possible, with values up to 50%, but always without compromising the user experience; or in other words, the comfort in obtaining water.

Is not only water, but also reduces the energy required to heat it, which translates into lower energy consumption.

Las griferías certificadas UWLA, como las que desarrollamos en Grifería Clever, están diseñadas para limitar el caudal de agua todo lo que sea posible, con valores que pueden alcanzar el 50%, pero siempre sin comprometer la experiencia del usuario; es decir, el confort en la obtención del agua. Con ello, no solo se ahorra agua, sino que también se reduce la energía requerida para calentarla, que se traduce en un menor consumo energético.

Économie d'eau et d'énergie

Les robinets certifiés UWLA, comme tous ceux que nous développons chez Clever Robinetterie, sont conçus pour limiter au maximum le débit d'eau, avec des valeurs arrivant jusqu'à 50% (comparé à un produit standard), mais sans altérer l'expérience de l'utilisateur. En d'autres termes, en maintenant le confort d'obtention de l'eau. Cela permet non seulement d'économiser l'eau, mais aussi de réduire l'énergie nécessaire pour la chauffer, ce qui se traduit par une réduction de la consommation d'énergie.

Environmental sustainability

By reducing water and energy consumption, we are contributing directly to the preservation of the planet's natural resources and the mitigation of the climate change.

Quando se reduce el consumo de agua y de energía, estamos contribuyendo de manera directa a la preservación de los recursos naturales del planeta y a la mitigación del cambio climático.

Développement durable

En limitant notre consommation d'eau et d'énergie, nous contribuons directement à la préservation des ressources naturelles de la planète et à la réduction de notre impact sur le changement climatique.

Short-term financial savings

By choosing a product with the UWLA label, the user is guaranteed to have chosen a product that will help him to save water and energy in a smarter and more efficient way.

This can make a difference in consumption; because the 70% of the water consumed in a house is dedicated to washing and personal hygiene, while 25% of the energy consumed is used to heat the water.

Al elegir un producto con la distinción UWLA el usuario tiene la garantía de haber elegido un producto que le ayudará a consumir agua y energía de una forma más inteligente y eficiente. Algo que, sin duda, puede marcar la diferencia en el consumo ya que el 70% del agua consumida en un hogar se dedica a funciones de lavado e higiene personal, mientras que un 25% de la energía que se consume tiene como objetivo calentar dicha agua.

Économies financières à court terme

En choisissant un produit avec la distinction UWLA, l'utilisateur a la garantie d'avoir choisi un produit qui l'aidera à consommer l'eau et l'énergie de manière plus intelligente et plus efficace. En effet, 70% de l'eau consommée dans un ménage est utilisée pour le lavage et l'hygiène personnelle, tandis que 25% de l'énergie consommée sert à chauffer l'eau.

Velvet · Rocket
 Antígona · Alpina
 Chef · Agora xtreme...

Clever tenemos En Grifería referencias que cuentan con esta certificación

La Robinetterie Clever possède plus de 100 références avec cette certification

Clever taps has more than

+100

references that have this certification

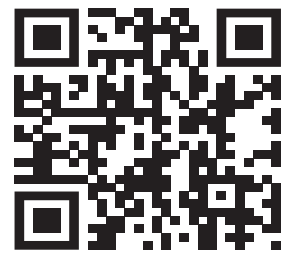

Check here all the available references

*Consulta aquí todas las referencias disponibles
 Voir toutes les références disponibles ici*

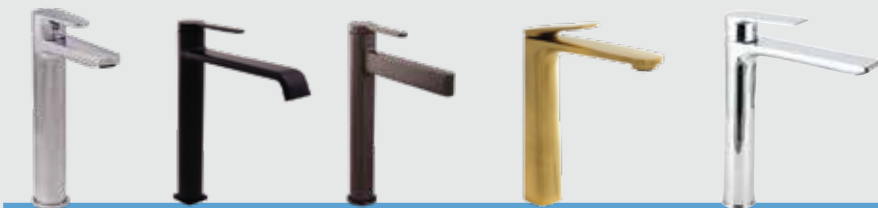

LABEL INCLUDED IN OUR PACKAGING

Etiqueta incluida en nuestro packaging

Étiquette incluse dans la boîte

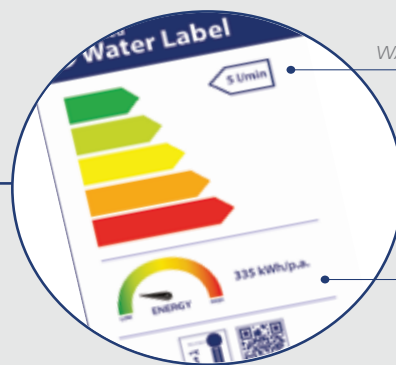

WATER SAVING. FLOW LIMITATION

Ahorro de agua.
 Limitación del caudal
*Économie d'eau.
 Limitation de débit*

ENERGY SAVING

Ahorro de energía
Économie d'énergie

CHARACTERISTIC ICONOGRAPHY

Iconografía características *Icônes de caractéristiques des produits*

THE MOST ADVANCED TECHNOLOGY

LA TECNOLOGÍA MÁS AVANZADA

La technologie la plus avancée

BASIN

Lavabo / Mitigeur lavabo

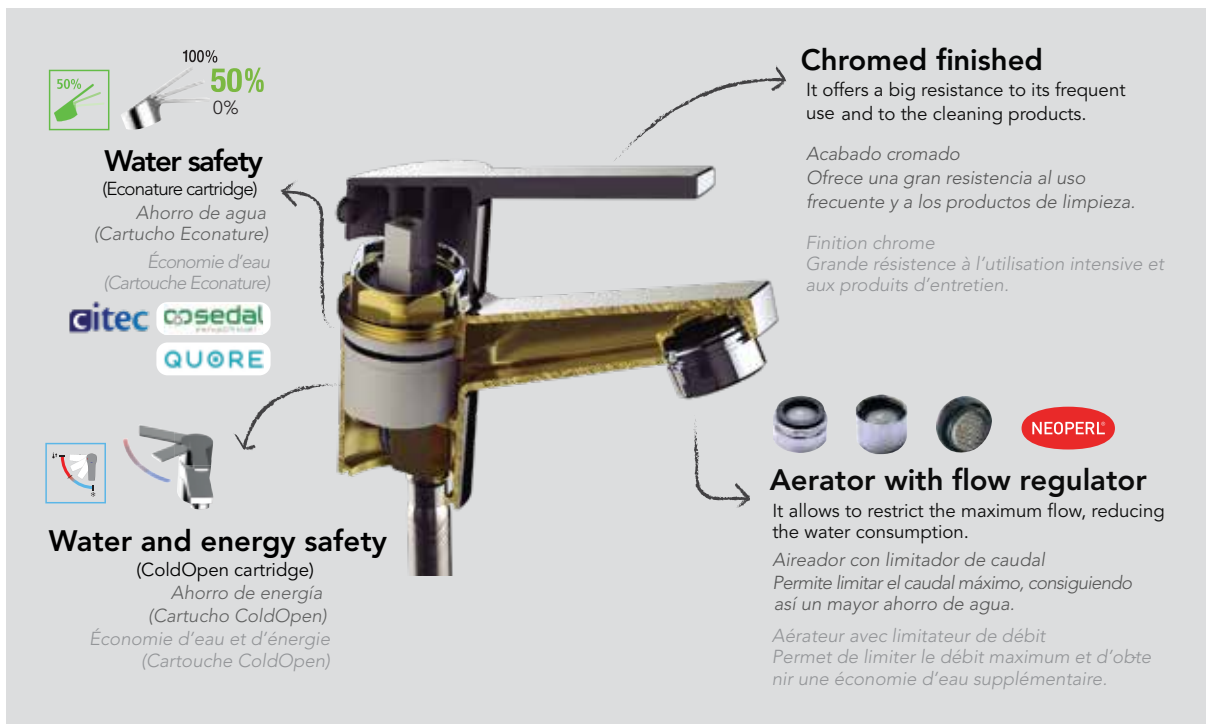

Water safety
(Econature cartridge)
Ahorro de agua
(Cartucho Econature)
Économie d'eau
(Cartouche Econature)

Water and energy safety
(ColdOpen cartridge)
Ahorro de energía
(Cartucho ColdOpen)
Économie d'eau et d'énergie
(Cartouche ColdOpen)

Chromed finished
It offers a big resistance to its frequent use and to the cleaning products.

Acabado cromado
Ofrece una gran resistencia al uso frecuente y a los productos de limpieza.

Finition chrome
Grande résistance à l'utilisation intensive et aux produits d'entretien.

Aerator with flow regulator
It allows to restrict the maximum flow, reducing the water consumption.

Aireador con limitador de caudal
Permite limitar el caudal máximo, consiguiendo así un mayor ahorro de agua.

Aérateur avec limitateur de débit
Permet de limiter le débit maximum et d'obtenir une économie d'eau supplémentaire.

50%
100%
50%
0%

gitec cosedal QUORE

NEOPERL

BATH-SHOWER

BAÑO-DUCHA / Mitigeur bain-douche



Automatic Diverter
Warranties the opening at bath position.

Inversor automático
Garantiza la apertura en posición baño.

Inverseur automatique
Garantit l'ouverture en position bain.

Sound reducer $\leq 30\text{dB}$
Comfort and rest for the guests.

Reductor de sonido $\leq 30\text{dB}$
Confort y descanso para los huéspedes

Système de réduction du bruit $\leq 30\text{dB}$
Confort et repos.

Check valve. Avoids the water flows
(According to the norm UNE EN-13959).

Dispositivo anti-retorno
Evita el reflujo del agua
(Cumple con la norma UNE EN-13959).

Système anti-retour. Evite le reflux de l'eau
(Répond à la norme UNE EN-13959).

NEOPERL



SAVINGS

30%



Technology AIR

AIR Technology. Clever handsets and shower heads use an AIR Advance Technology. Injecting air before the water outlet, offering you a shower with a softer and more comfortable sensation.

Los teléfonos y rociadores de ducha Clever usan la tecnología AIR Advanced. Inyectando aire antes de la salida del agua, se consigue dar volumen a las gotas obteniendo una sensación más suave y confortable en la ducha.

Technologie AIR. Les douchettes et les pommes de douche Clever sont équipées de la technologie AIR Advanced. L'injection d'air avant la sortie d'eau permet de donner du volume aux gouttes et d'obtenir une sensation plus douce et confortable sous la douche.



Flow regulator It restricts the maximum flow, getting higher water savings.

Regulador con limitador. Permite limitar el caudal máximo, consiguiendo así un mayor ahorro de agua.
Régulateur avec limitateur. Permet de limiter le débit maximum et d'obtenir une économie d'eau supplémentaire.

THERMOSTATICS

Thermostaticos / Thermostatiques



Ceramic cartridge antilime

Carries out the ON/OFF flow functions and distribution. High resistance. It allows 200.000 openings.

Cartucho cerámico anticalcáreo. Realiza las funciones de caudal ON/OFF y distribución. Gran resistencia. Permite 200.000 maniobras.

Cartouche céramique anticalcaire. Pour les fonctions de débit ON/OFF et de distribution. Grande résistance, permet 200.000 mouvements.



Thermostatics

The temperature keeps constant saving water, it avoids scalding if the cold water is interrupted. Easy maintainance.

Thermostáticos. La temperatura permanece constante ahorrando agua, y además se evitan quemaduras si el suministro de agua fría se interrumpe. Fácil mantenimiento.

Cartouche thermostatique. Permet de maintenir une température constante et d'éviter les brûlures en coupant l'arrivée d'eau chaude si le débit d'eau froide est interrompu. Entretien facile.



Cold-touch, anti scald mixers

This system assure that the mixer's body will never be hot to scald anyone

Cold-touch, grifería anti-quemaduras. Este sistema permite que en ningún caso el cuerpo de la grifería se caliente y queme. Ideal para la seguridad infantil.

Système Cold-touch anti brûlures. Évite que le corps de la robinetterie ne chauffe et ne brûle. Idéal pour la sécurité des enfants.







Quick guide

with special finishes

Guía rápida con todos nuestros acabados
Guide rapide finitions spéciales



Chrome
Cromado
Chromé



Matt black
Black mate
Noir mat



Bronze
Bronze
Bronze



Brushed nickel
Niquel cepillado
Nickel brossé
(PVD)



Brushed gunmetal
Gunmetal cepillado
Gunmetal brossé
(PVD)



Brushed gold
Oro cepillado
Or brossé
(PVD)

PVD Finishing technique / (Physical Vapor Deposition)

ACABADOS MEDIANTE LA TÉCNICA PVD

Finition par traitement PVD



PVD coating technology has an extra corrosion resistance that offers greater durability, as well as being a clean and sustainable process.

La tecnología de recubrimiento PVD tiene una resistencia extra a la corrosión que ofrece mayor durabilidad, además de ser un proceso limpio y sostenible.

La technologie de revêtement PVD offre une résistance supplémentaire à la corrosion pour une plus grande durabilité. Il s'agit par ailleurs d'un procédé propre et durable.



18 BATHROOM

- 18 MARTI
- 20 MANTA
- 24 CARDONA
- 26 VELVET
- 36 ANTIGONA
- 38 AGORA XTREME
- 42 HAZE
- 44 GO!
- 50 ROCKET
- 54 ARAYA MERCIA
- 58 PERFORMA

60 SHOWERS & SHATAFS

- 60 UP! URBAN
- 62 GO!
- 66 IDEAL
- 68 HYGIENIC SHOWERS

70 SHOWER ACCESSORIES

- 70 SLIDING BAR SETS
- 71 SHOWER HEADS
- 72 SHOWER HEAD HANDSET
- 74 SHOWER HOSES
- 76 BOTTLE TRAPS
- 78 POP UP WASTES

82 KITCHEN

- 82 ALPINA
- 88 4IN1 INSTANT HOT WATER TAP
- 90 CHEF
- 92 WATER FILTRATION
- 96 ANTIGONA
- 98 RUNE
- 100 ELEKTRO
- 101 ARBON
- 102 TORMES
- 104 GO!
- 105 ROCKET
- 106 PICA
- 108 ARAYA MERCIA
- 112 PERFORMA



MONO BASIN MIXER

Lavabo
Mitigeur lavabo



Single-lever basin mixer with aerator and flexible hoses 1/2" >350mm.
Lavabo monomando con aireador y flexibles 1/2" >350mm.
Mitigeur lavabo avec aérateur et flexibles de raccordement 1/2" >350mm.

REF.	RRP INC VAT	UOM
4k6071UK  3.2l/min	143.99	PCS



MINI MONO BASIN MIXER

Lavabo
Mitigeur lavabo



Single-lever basin mixer with aerator and flexible hoses 1/2" >350mm.
Lavabo monomando con aireador y flexibles 1/2" >350mm.
Mitigeur lavabo avec aérateur et flexibles de raccordement 1/2" >350mm.

REF.	RRP INC VAT	UOM
4k6070UK  3.4l/min	131.99	PCS



BATH FILLER

Ducha del baño
Bain douche

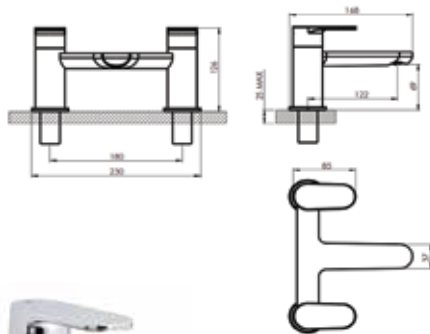

REF.	RRP INC VAT	UOM
4k6072UK	233.99	PCS



BATH SHOWER MIXER

Mezclador de la ducha
Mitigeur de douche

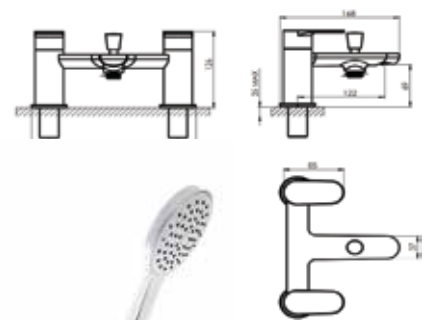

REF.	RRP INC VAT	UOM
4k6073UK	293.99	PCS





MONO BASIN MIXER

Lavabo
Mitigeur lavabo

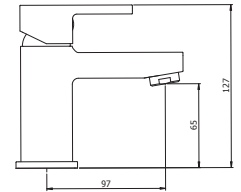

Single-lever basin mixer with aerator and flexible hoses 1/2" >350mm.

Lavabo monomando con aireador y flexibles 1/2" >350mm.

Mitigeur lavabo avec aérateur et flexibles de raccordement 1/2" >350mm.

REF.	RRP INC VAT	UOM
922057UK  4 l/min	155.99	PCS



MINI MONO BASIN MIXER

Lavabo
Mitigeur lavabo

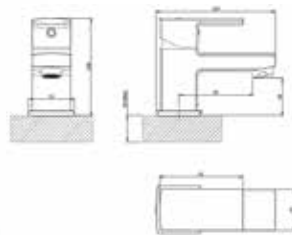

Single-lever basin mixer with aerator and flexible hoses 1/2" >350mm.

Lavabo monomando con aireador y flexibles 1/2" >350mm.

Mitigeur lavabo avec aérateur et flexibles de raccordement 1/2" >350mm.

REF.	RRP INC VAT	UOM
922056UK  5 l/min	149.99	PCS



BIDET MIXER

Bide
Mitigeur bidet

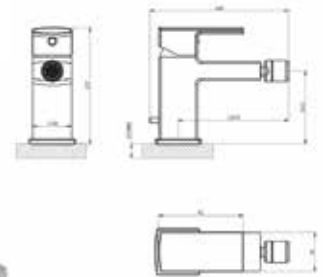

REF.	RRP INC VAT	UOM
4k5007UK  4 l/min	149.99	PCS



BASIN TAP PAIR
 Lavabo 100
 Mitigeur lavabo 100

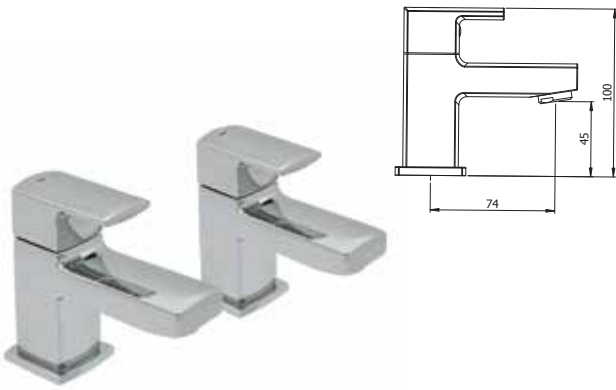

REF.	RRP INC VAT	UOM
4S8001UK	179.99	PCS



BATH TAP PAIR
 Grifo de bano
 Robinet de bain

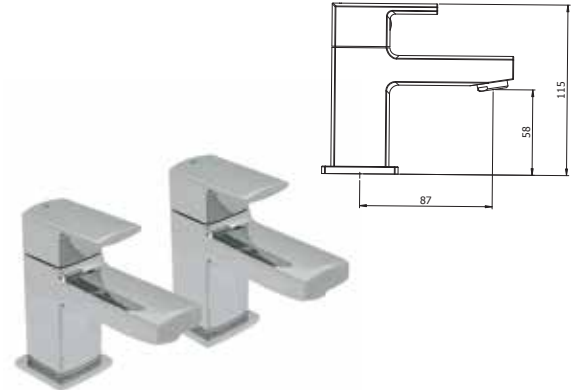

REF.	RRP INC VAT	UOM
4S8002UK	203.99	PCS



BATH FILLER
 Ducha del bano
 Bain douche

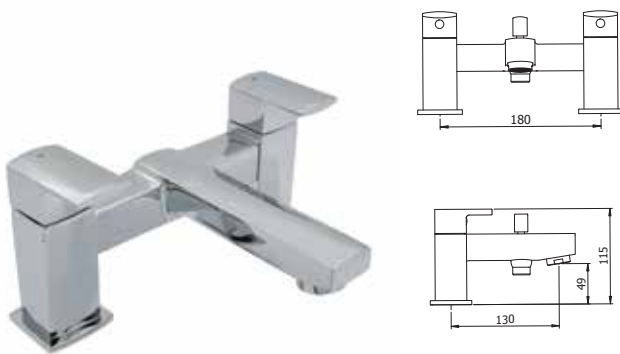

REF.	RRP INC VAT	UOM
922058UK	227.99	PCS



BATH SHOWER MIXER
 Mezclador de la ducha
 Mitigeur de douche

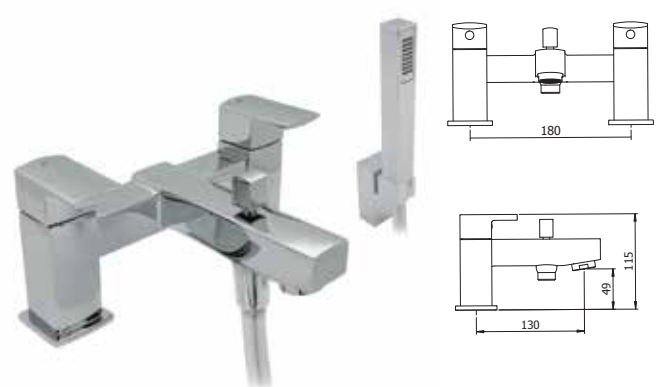

REF.	RRP INC VAT	UOM
922059UK	305.99	PCS



Manta Black



MONO BASIN MIXER

Lavabo
Mitigeur lavabo

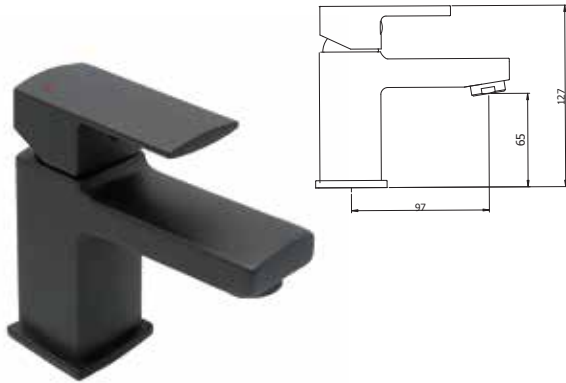

Single-lever basin mixer with aerator and flexible hoses 1/2" >350mm.
Lavabo monomando con aireador y flexibles 1/2" >350mm.
Mitigeur lavabo avec aérateur et flexibles de raccordement 1/2" >350mm.

REF.	RRP INC VAT	UOM
4S8009UK  4 l/min	161.99	PCS



MINI MONO BASIN MIXER

Lavabo
Mitigeur lavabo

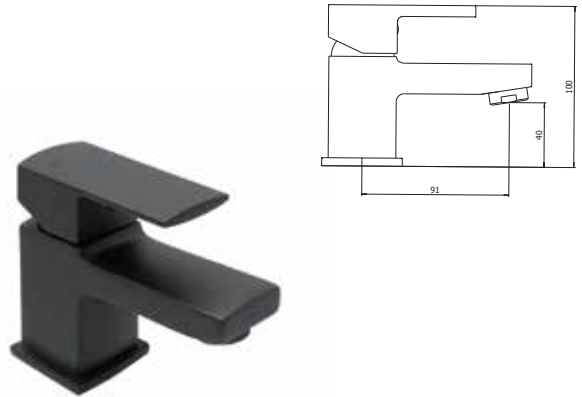

Single-lever basin mixer with aerator and flexible hoses 1/2" >350mm.
Lavabo monomando con aireador y flexibles 1/2" >350mm.
Mitigeur lavabo avec aérateur et flexibles de raccordement 1/2" >350mm.

REF.	RRP INC VAT	UOM
4S8012UK  5 l/min	161.99	PCS



BATH FILLER

Ducha del baño
Bain douche

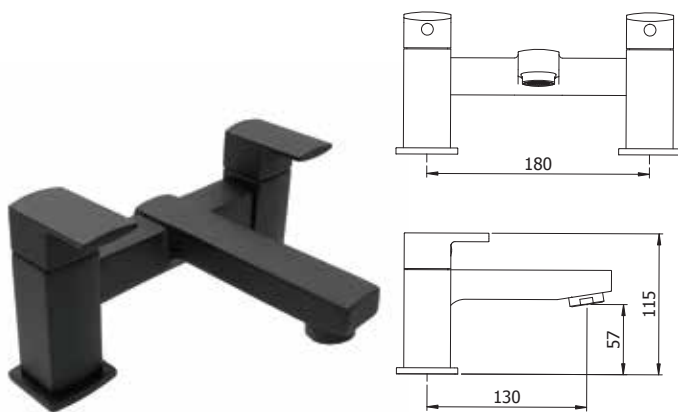

REF.	RRP INC VAT	UOM
4S8010UK	251.99	PCS



BATH SHOWER MIXER

Mezclador de la ducha
Mitigeur de douche

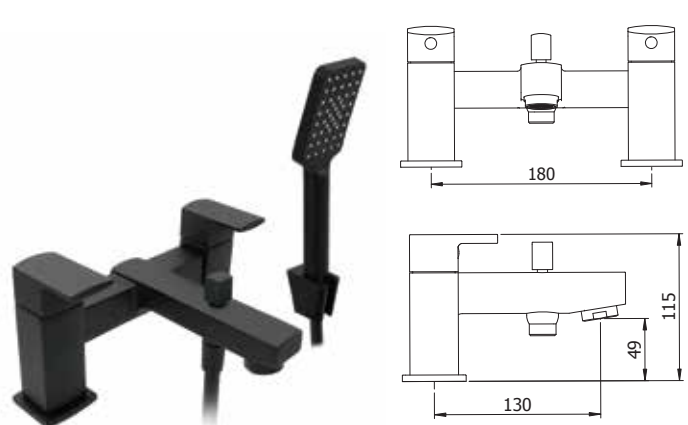

REF.	RRP INC VAT	UOM
4S8011UK	365.99	PCS





MONO BASIN MIXER
Lavabo
Mitigeur lavabo

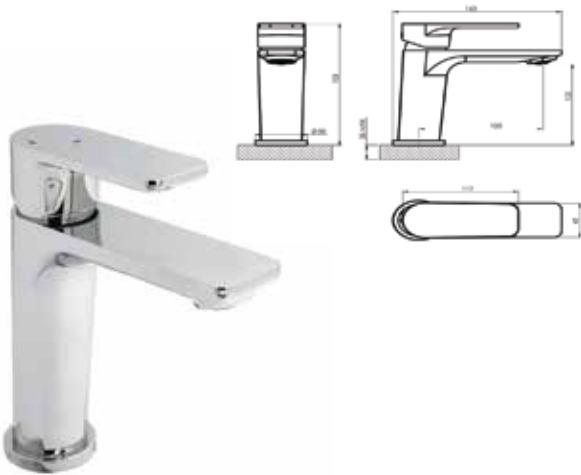

Single-lever basin mixer with aerator and flexible hoses 1/2" >350mm.
Lavabo monomando con aireador y flexibles 1/2" >350mm.
Mitigeur lavabo avec aérateur et flexibles de raccordement 1/2" >350mm.

REF.	RRP INC VAT	UOM
4K6075UK  3.2 l/min	143.99	PCS



MINI MONO BASIN MIXER
Lavabo
Mitigeur lavabo

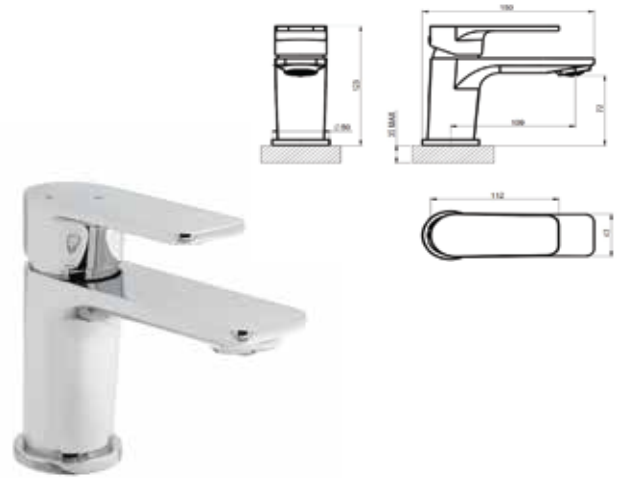

Single-lever basin mixer with aerator and flexible hoses 1/2" >350mm.
Lavabo monomando con aireador y flexibles 1/2" >350mm.
Mitigeur lavabo avec aérateur et flexibles de raccordement 1/2" >350mm.

REF.	RRP INC VAT	UOM
4K6074UK  3.5 l/min	131.99	PCS



BATH FILLER
Ducha del bano
Bain douche



REF.	RRP INC VAT	UOM
4K6076UK	233.99	PCS



BATH SHOWER MIXER
Mezclador de la ducha
Mitigeur de douche



REF.	RRP INC VAT	UOM
4K6077UK	293.99	PCS





TALL MONO BASIN MIXER

Lavabo 230

Mitigeur lavabo 230

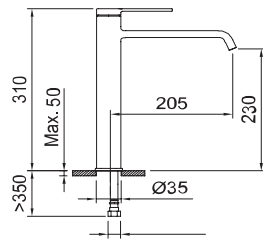

Single-lever tall basin mixer with aerator and flexible hoses 1/2" >350mm.
Lavabo alto monomando con aireador y flexibles 1/2" >350mm.
Mitigeur lavabo haut avec aérateur et flexibles de raccordement 1/2" >350mm.

REF.	Water Label	ACS	RRP INC VAT	UOM
61939UK	6 l/min		191.99	PCS



MONO BASIN MIXER

Lavabo 105

Mitigeur lavabo 105

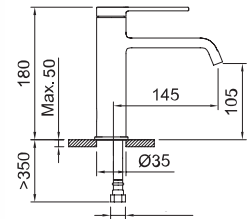

Single-lever basin mixer with aerator and flexible hoses 1/2" >350mm.
Lavabo monomando con aireador y flexibles 1/2" >350mm.
Mitigeur lavabo avec aérateur et flexibles de raccordement 1/2" >350mm.

REF.	Water Label	ACS	RRP INC VAT	UOM
61936UK	6 l/min		119.99	PCS



BATH SHOWER MIXER

Mezclador de la ducha

Mitigeur de douche



REF.	RRP INC VAT	UOM
TBC	TBC	PCS

BATH FILLER

Ducha del baño

Bain douche



REF.	RRP INC VAT	UOM
TBC	TBC	PCS

RELATED PRODUCTS



Ref. 60702UK



Ref. 61122UK



Ref. 61118UK

Velvet I



TALL MONO BASIN MIXER

Lavabo 230
Mitigeur lavabo 230

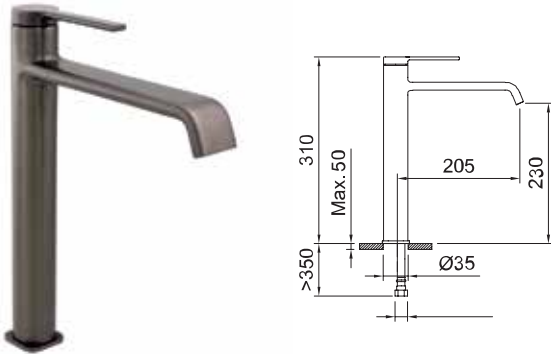

Single-lever tall basin mixer with aerator and flexible hoses 1/2" >350mm.
Lavabo alto monomando con aireador y flexibles 1/2" >350mm.
Mitigeur lavabo haut avec aérateur et flexibles de raccordement 1/2" >350mm.

REF.	Water Label	RRP INC VAT	UOM
61940UK	6 l/min	227.99	PCS



BATH SHOWER MIXER

Mezclador de la ducha
Mitigeur de douche



REF.	RRP INC VAT	UOM
TBC	TBC	PCS

MONO BASIN MIXER

Lavabo 105
Mitigeur lavabo 105

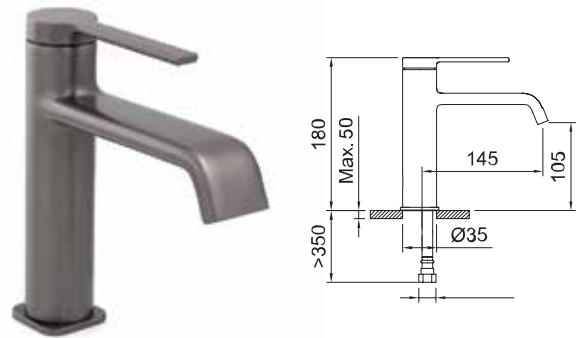

Single-lever basin mixer with aerator and flexible hoses 1/2" >350mm.
Lavabo monomando con aireador y flexibles 1/2" >350mm.
Mitigeur lavabo avec aérateur et flexibles de raccordement 1/2" >350mm.

REF.	Water Label	RRP INC VAT	UOM
61937UK	6 l/min	155.99	PCS



BATH FILLER

Ducha del baño
Bain douche



REF.	RRP INC VAT	UOM
TBC	TBC	PCS

RELATED PRODUCTS



Ref. 61978UK

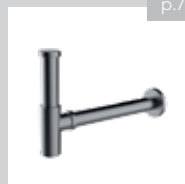

Ref. 61976UK

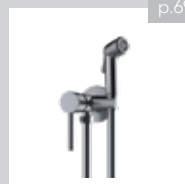

Ref. 61974UK

Velvet I

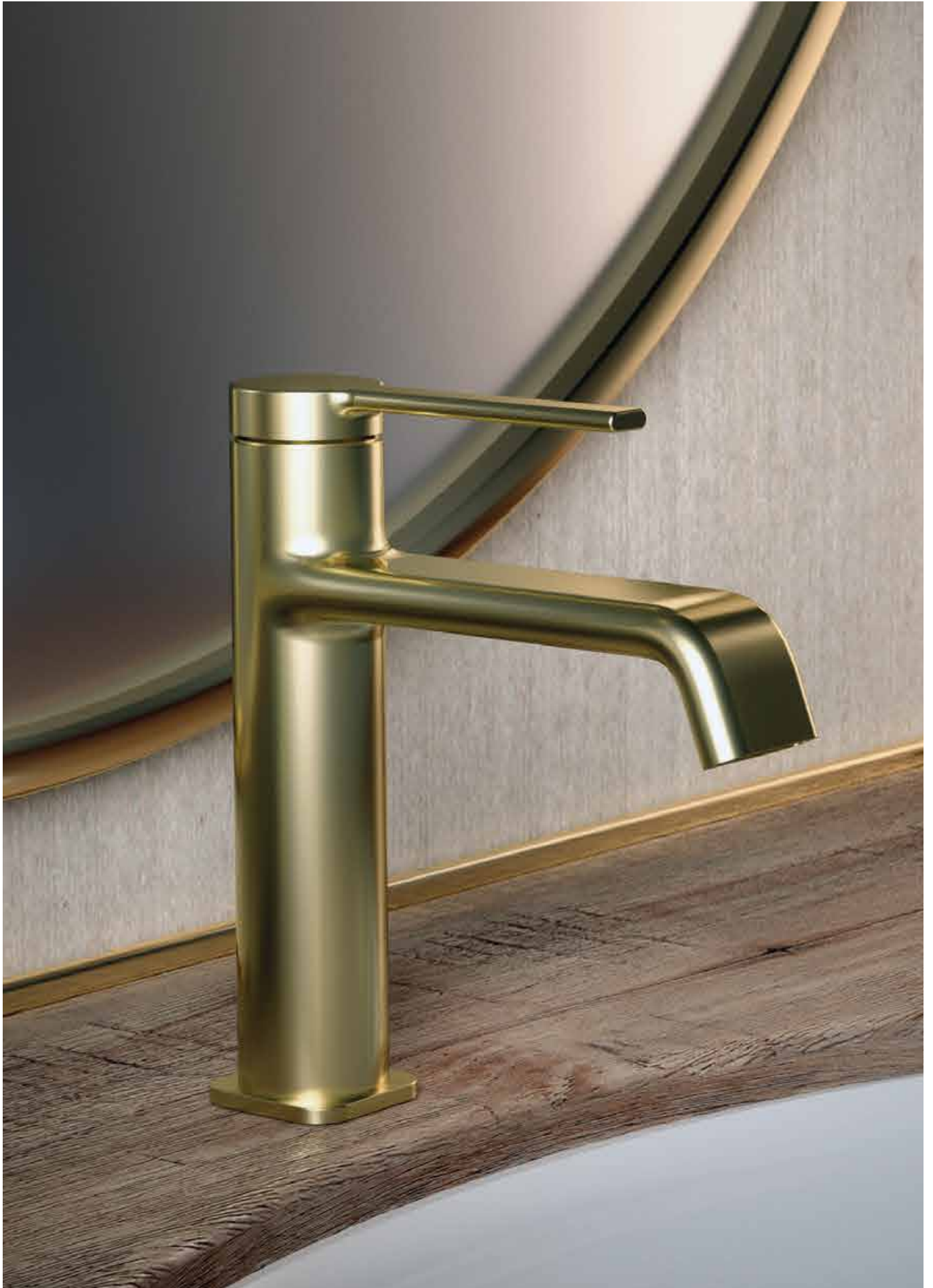

TALL MONO BASIN MIXER

Lavabo 230
Mitigeur lavabo 230

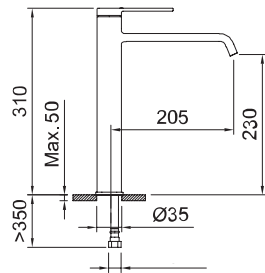

Single-lever tall basin mixer with aerator and flexible hoses 1/2" >350mm.
Lavabo alto monomando con aireador y flexibles 1/2" >350mm.
Mitigeur lavabo haut avec aérateur et flexibles de raccordement 1/2" >350mm.

REF.	Water Label	RRP INC VAT	UOM
61941UK	6 l/min	215.99	PCS



BATH SHOWER MIXER
Mezclador de la ducha
Mitigeur de douche



REF.	RRP INC VAT	UOM
TBC	TBC	PCS

MONO BASIN MIXER

Lavabo 105
Mitigeur lavabo 105

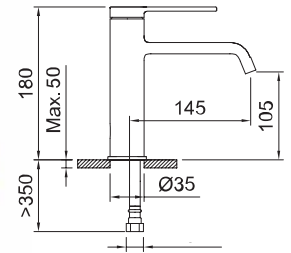

Single-lever basin mixer with aerator and flexible hoses 1/2" >350mm.
Lavabo monomando con aireador y flexibles 1/2" >350mm.
Mitigeur lavabo avec aérateur et flexibles de raccordement 1/2" >350mm.

REF.	Water Label	RRP INC VAT	UOM
61938UK	6 l/min	155.99	PCS



BATH FILLER
Ducha del baño
Bain douche



REF.	RRP INC VAT	UOM
TBC	TBC	PCS

RELATED PRODUCTS

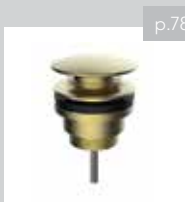

Ref. 61979UK



Ref. 61977UK

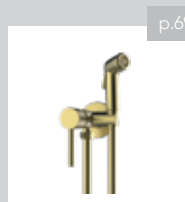

Ref. 61975UK

Velvet II



TALL MONO BASIN MIXER

Lavabo 225
Mitigeur lavabo 225

MONO BASIN MIXER

Lavabo 110
Mitigeur lavabo 110

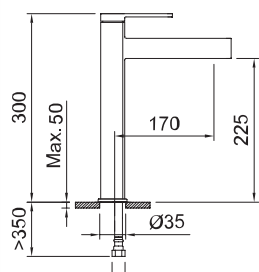

Single-lever tall basin mixer with aerator and flexible hoses 1/2" >350mm.
Lavabo alto monomando con aireador y flexibles 1/2" >350mm.
Mitigeur lavabo haut avec aérateur et flexibles de raccordement 1/2" >350mm.

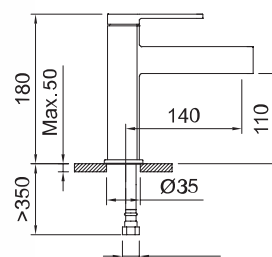

Single-lever basin mixer with aerator and flexible hoses 1/2" >350mm.
Lavabo monomando con aireador y flexibles 1/2" >350mm.
Mitigeur lavabo avec aérateur et flexibles de raccordement 1/2" >350mm.

REF.	Water Label	RRP INC VAT	UOM
61945UK	7 l/min	227.99	PCS

REF.	Water Label	RRP INC VAT	UOM
61942UK	7 l/min	155.99	PCS



RELATED PRODUCTS

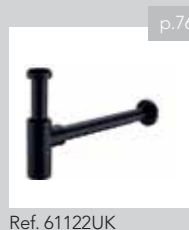

TALL MONO BASIN MIXER
Lavabo 225
Mitigeur lavabo 225

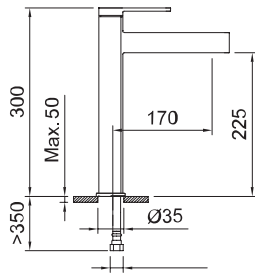

Single-lever tall basin mixer with aerator and flexible hoses 1/2" >350mm.
Lavabo alto monomando con aireador y flexibles 1/2" >350mm.
Mitigeur lavabo haut avec aérateur et flexibles de raccordement 1/2" >350mm.

REF.	Unified Water Label	RRP INC VAT	UOM
61946UK	7 l/min	263.99	PCS



TALL MONO BASIN MIXER
Lavabo 225
Mitigeur lavabo 225

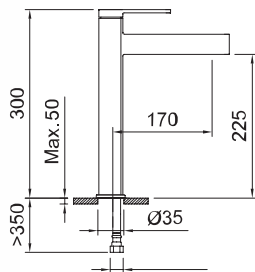

Single-lever tall basin mixer with aerator and flexible hoses 1/2" >350mm.
Lavabo alto monomando con aireador y flexibles 1/2" >350mm.
Mitigeur lavabo haut avec aérateur et flexibles de raccordement 1/2" >350mm.

REF.	Unified Water Label	RRP INC VAT	UOM
61947UK	7 l/min	251.99	PCS



MONO BASIN MIXER
Lavabo 110
Mitigeur lavabo 110

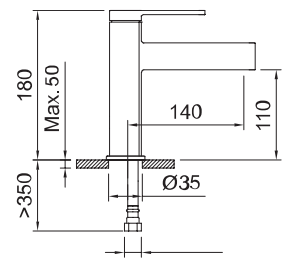

Single-lever basin mixer with aerator and flexible hoses 1/2" >350mm.
Lavabo monomando con aireador y flexibles 1/2" >350mm.
Mitigeur lavabo avec aérateur et flexibles de raccordement 1/2" >350mm.

REF.	Unified Water Label	RRP INC VAT	UOM
61943UK	7 l/min	191.99	PCS



MONO BASIN MIXER
Lavabo 110
Mitigeur lavabo 110

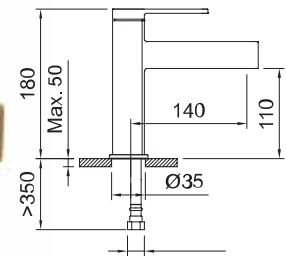

Single-lever basin mixer with aerator and flexible hoses 1/2" >350mm.
Lavabo monomando con aireador y flexibles 1/2" >350mm.
Mitigeur lavabo avec aérateur et flexibles de raccordement 1/2" >350mm.

REF.	Unified Water Label	RRP INC VAT	UOM
61944UK	7 l/min	179.99	PCS



RELATED PRODUCTS

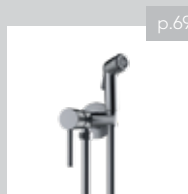

Ref. 61974UK

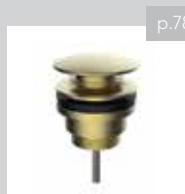

Ref. 61979UK



Ref. 61977UK

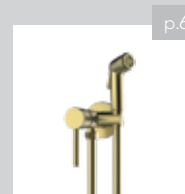

Ref. 61975UK

Velvet III



TALL MONO BASIN MIXER

Lavabo 230
Mitigeur lavabo 230

MONO BASIN MIXER

Lavabo 100
Mitigeur lavabo 100

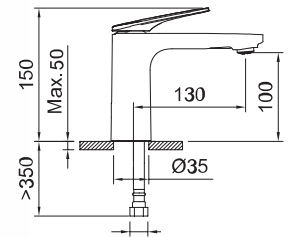
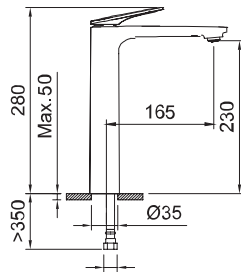

Single-lever tall basin mixer with aerator and flexible hoses 1/2" >350mm.
Lavabo alto monomando con aireador y flexibles 1/2" >350mm.
Mitigeur lavabo haut avec aérateur et flexibles de raccordement 1/2" >350mm.

Single-lever basin mixer with aerator and flexible hoses 1/2" >350mm.
Lavabo monomando con aireador y flexibles 1/2" >350mm.
Mitigeur lavabo avec aérateur et flexibles de raccordement 1/2" >350mm.

REF.	Unified Water Label	RRP INC VAT	UOM
61951UK	5 l/min	203.99	PCS

REF.	Unified Water Label	RRP INC VAT	UOM
61948UK	5 l/min	131.99	PCS



RELATED PRODUCTS



Ref. 60702UK

p.78

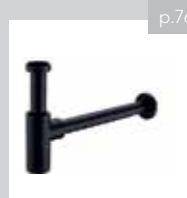

Ref. 61122UK

p.76

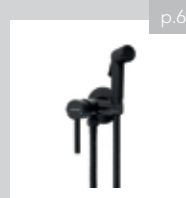

Ref. 61118UK

p.69



Ref. 61978UK

p.78



Ref. 61976UK

p.76

TALL MONO BASIN MIXER

Lavabo 230
Mitigeur lavabo 230

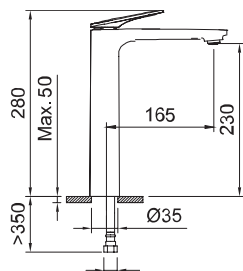

Single-lever tall basin mixer with aerator and flexible hoses 1/2" >350mm.
Lavabo alto monomando con aireador y flexibles 1/2" >350mm.
Mitigeur lavabo haut avec aérateur et flexibles de raccordement 1/2" >350mm.

REF.	Water Label	ACS	RRP INC VAT	UOM
61952UK	5 l/min		239.99	PCS



TALL MONO BASIN MIXER

Lavabo 230
Mitigeur lavabo 230

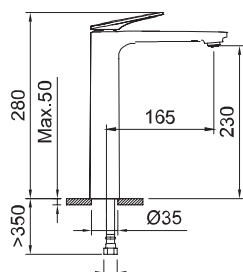

Single-lever tall basin mixer with aerator and flexible hoses 1/2" >350mm.
Lavabo alto monomando con aireador y flexibles 1/2" >350mm.
Mitigeur lavabo haut avec aérateur et flexibles de raccordement 1/2" >350mm.

REF.	Water Label	ACS	RRP INC VAT	UOM
61953UK	5 l/min		227.99	PCS



MONO BASIN MIXER

Lavabo 100
Mitigeur lavabo 100

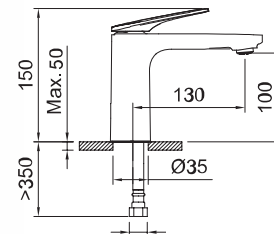

Single-lever basin mixer with aerator and flexible hoses 1/2" >350mm.
Lavabo monomando con aireador y flexibles 1/2" >350mm.
Mitigeur lavabo avec aérateur et flexibles de raccordement 1/2" >350mm.

REF.	Water Label	ACS	RRP INC VAT	UOM
61949UK	5 l/min		167.99	PCS



MONO BASIN MIXER

Lavabo 100
Mitigeur lavabo 100

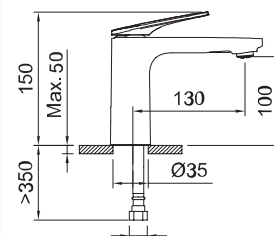

Single-lever basin mixer with aerator and flexible hoses 1/2" >350mm.
Lavabo monomando con aireador y flexibles 1/2" >350mm.
Mitigeur lavabo avec aérateur et flexibles de raccordement 1/2" >350mm.

REF.	Water Label	ACS	RRP INC VAT	UOM
61950UK	5 l/min		155.99	PCS



RELATED PRODUCTS



Ref. 61974UK



Ref. 61979UK



Ref. 61977UK



Ref. 61975UK



94474UK
antigona

MINI MONO BASIN MIXER

Lavabo 65
Mélangeur lavabo 65

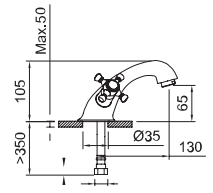

Two-handled basin mixer with aerator and flexible hoses 1/2" >350mm.
Lavabo bimando con aireador y flexibles 1/2" >350mm.
Mélangeur lavabo avec aérateur et flexibles de raccordement 1/2" >350mm.

REF.	RRP INC VAT	UOM
94474UK	107.99	PCS



MONO BASIN MIXER

Lavabo 120
Mélangeur lavabo 120

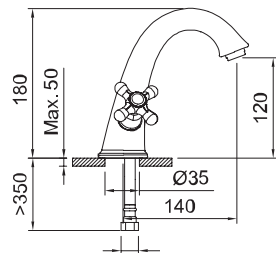

Two-handled basin mixer with aerator and flexible hoses 1/2" >350mm.
Lavabo bimando con aireador y flexibles 1/2" >350mm.
Mélangeur lavabo avec aérateur et flexibles de raccordement 1/2" >350mm.

REF.	RRP INC VAT	UOM
61765UK	179.99	PCS



THREE HOLE DECK BASIN

Lavabo repisa 105
Mélangeur lavabo 3 trous 105

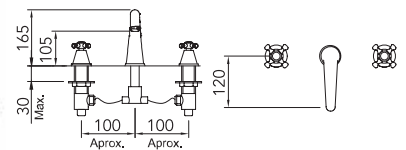

Deck-mounted two-handle basin mixer with three holes, aerator and flexible hoses 300mm.
Lavabo bimando repisa con tres orificios, aireador y flexibles 300mm.
Mélangeur lavabo sur plage trois trous avec aérateur et flexibles de raccordement 300mm.

REF.	RRP INC VAT	UOM
98426UK	281.99	PCS



BIDET MIXER

Bide 75
Mélangeur bidet 75

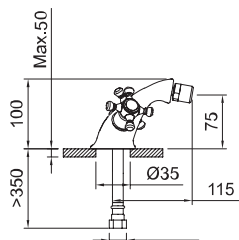

Two-handled bidet mixer with swivel aerator and flexible hoses 1/2" >350mm.
Bidé bimando con aireador a rótula y flexibles 1/2" >350mm.
Mélangeur bidet avec aérateur rotule et flexibles de raccordement 1/2" >350mm.

REF.	RRP INC VAT	UOM
97928UK	107.99	PCS



BATH SHOWER MIXER

Bano-ducha
Mélangeur bain-douche



Includes
Incluye
Inclus

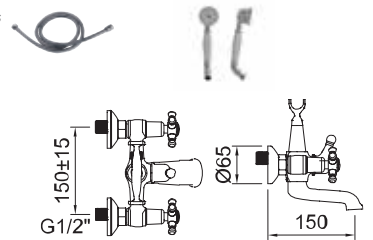

Two-handled bath-shower mixer with diverter.
Baño-ducha bimando con inversor.

REF.	RRP INC VAT	UOM
94476UK	317.99	PCS





MONO BASIN MIXER

Lavabo 125
Mélangeur lavabo 125

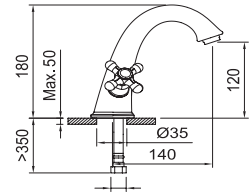

Two-handed basin mixer with aerator and flexible hoses 1/2" >350mm.
Lavabo bimando con aireador y flexibles 1/2" >350mm.
Mélangeur lavabo avec aérateur et flexibles de raccordement 1/2" >350mm.

REF.	Unified Water Label	RRP INC VAT	UOM
61766UK	5 l/min	203.99	PCS



MINI MONO BASIN MIXER

Lavabo 65
Mélangeur lavabo 65

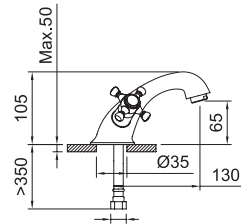

Two-handed basin mixer with aerator and flexible hoses 1/2" >350mm.
Lavabo bimando con aireador y flexibles 1/2" >350mm.
Mélangeur lavabo avec aérateur et flexibles de raccordement 1/2" >350mm.

REF.	Unified Water Label	RRP INC VAT	UOM
61764UK	5 l/min	125.99	PCS



BIDET MIXER

Bide 75
Mélangeur bidet 75

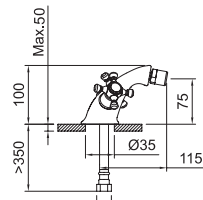

Two-handed bidet mixer with swivel aerator and flexible hoses 1/2" >350mm.
Bidé bimando con aireador a rótula y flexibles 1/2" >350mm.
Mélangeur bidet avec aérateur rotule et flexibles de raccordement 1/2" >350mm.

REF.	Unified Water Label	RRP INC VAT	UOM
61768UK	5 l/min	125.99	PCS



BATH SHOWER MIXER

Bano-ducha
Mélangeur bain-douche

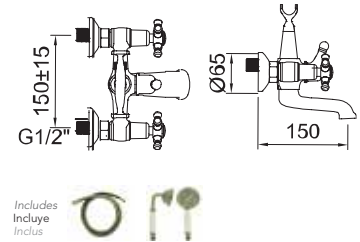

Includes
Incluye
Inclus

Two-handed bath-shower mixer with diverter.
Baño-ducha bimando con inversor.
Mélangeur bain-douche avec inverseur.

REF.	RRP INC VAT	UOM
61769UK	341.99	PCS



RELATED PRODUCTS



Ref. 61819UK



Ref. 61820UK



60100UK
AGORA xtreme

MONO BASIN MIXER

Lavabo105
Mitigeur lavabo 105

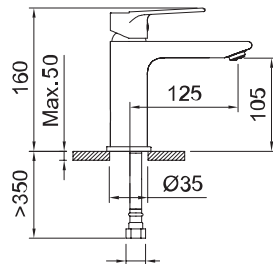

Single-lever basin mixer with aerator and flexible hoses 1/2" >350mm.
Lavabo monomando con aireador y flexibles 1/2" >350mm.
Mitigeur lavabo avec aérateur et flexibles de raccordement 1/2" >350mm.

REF.	RRP INC VAT	UOM
60100UK   	131.99	PCS



BASIN TAP PAIR

Grifo para lavabo
Robinet de lavabo



REF.	RRP INC VAT	UOM
TBC	TBC	PCS

BATH TAP PAIR

Grifo de baño
Robinet de bain

BATH FILLER

Ducha del baño
Bain douche

COMING SOON



COMING SOON



Bathroom - Agora xtreme

REF.	RRP INC VAT	UOM
TBC	TBC	PCS

REF.	RRP INC VAT	UOM
TBC	TBC	PCS

BATH SHOWER MIXER

Mezclador de la ducha
Mitigeur de douche

BIDET MIXER

Bide 65
Mitigeur bidet 65

COMING SOON

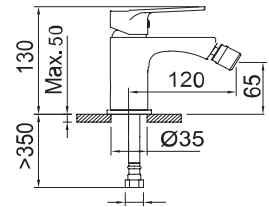

Single-lever bidet mixer with swivel aerator and flexible hoses 1/2" >350mm.
Bidé monomando con aireador a rótula y flexibles 1/2" >350mm.
Mitigeur bidet avec aérateur rotule et flexibles de raccordement 1/2" >350mm.

REF.	RRP INC VAT	UOM
TBC	TBC	PCS

REF.	RRP INC VAT	UOM
60106UK  5 l/min 	119.99	PCS





60705UK
AGORA xtreme

MONO BASIN MIXER

Lavabo105
Mitigeur lavabo 105

BASIN TAP PAIR

Grifo para lavabo
Robinet de lavabo

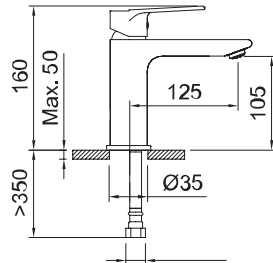

Single-lever basin mixer with aerator and flexible hoses 1/2" >350mm.
Lavabo monomando con aireador y flexibles 1/2" >350mm.
Mitigeur lavabo avec aérateur et flexibles de raccordement 1/2" >350mm.



REF.		RRP INC VAT	UOM
60705UK		143.99	PCS

REF.	RRP INC VAT	UOM
TBC	TBC	PCS

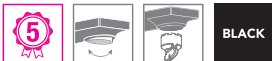

BATH TAP PAIR
Grifo de bano
Robinet de bain



REF.	RRP INC VAT	UOM
TBC	TBC	PCS

BATH FILLER
Ducha del bano
Bain douche



REF.	RRP INC VAT	UOM
TBC	TBC	PCS

BATH SHOWER MIXER
Mezclador de la ducha
Mitigeur de douche



REF.	RRP INC VAT	UOM
TBC	TBC	PCS

BIDET MIXER
Bide 65
Mitigeur bidet 65

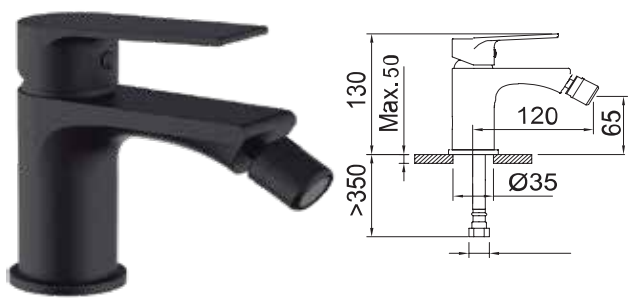

Single-lever bidet mixer with swivel aerator and flexible hoses 1/2" >350mm.
 Bidé monomando con aireador a rótula y flexibles 1/2" >350mm.
 Mitigeur bidet avec aérateur rotule et flexibles de raccordement 1/2" >350mm.

REF.	RRP INC VAT	UOM
61717UK  5 l/min 	131.99	PCS





MONO BASIN MIXER

Lavabo
Mitigeur lavabo

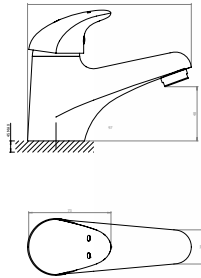

Single-lever basin mixer with flexible hoses 1/2" >350mm.
Lavabo monomando con flexibles 1/2" >350mm.
Mitigeur lavabo avec flexibles de raccordement 1/2" >350mm.

REF.	RRP INC VAT	UOM
4G4003UK	137.99	PCS



MINI MONO BASIN MIXER

Lavabo
Mitigeur lavabo

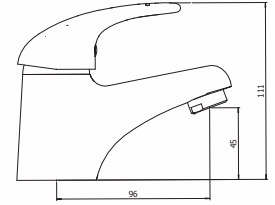

Single-lever basin mixer with aerator and flexible hoses 1/2" >350mm.
Lavabo monomando con aireador y flexibles 1/2" >350mm.
Mitigeur lavabo avec aérateur et flexibles de raccordement 1/2" >350mm.

REF.	RRP INC VAT	UOM
922072UK	125.99	PCS



BASIN TAP PAIR

Grifo para lavabo
Roboto de lavabo

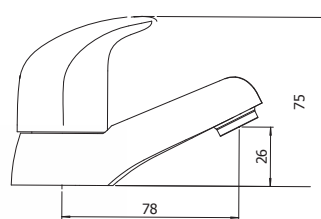

REF.	RRP INC VAT	UOM
922070UK	107.99	PCS



BATH FILLER

Ducha del bano
Bain douche

BATH SHOWER MIXER

Mezclador de la ducha
Mitigeur de douche

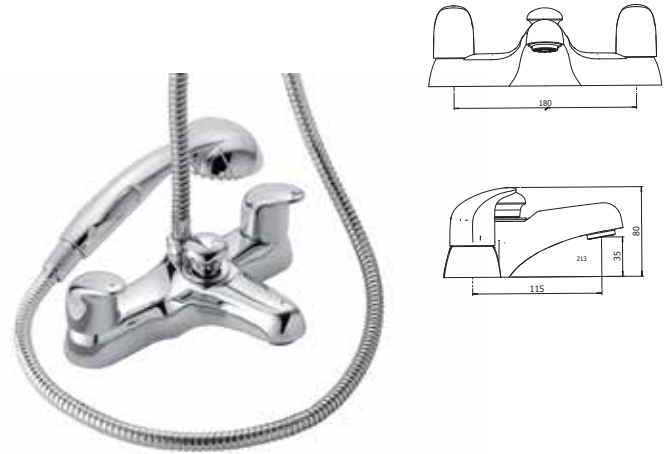

REF.	RRP INC VAT	UOM
922073UK	173.99	PCS



Low Pressure
Flow Straightener
Single Flow
Brass Backnut

REF.	RRP INC VAT	UOM
922074UK	233.99	PCS



Low Pressure
Flow Straightener
Single Flow
Brass Backnut
Shower Kit Included







MONO BASIN MIXER

Lavabo 100

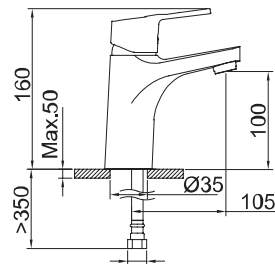
Mitigeur lavabo 100



Single-lever basin mixer with aerator and flexible hoses 1/2" >350mm.
Lavabo monomando con aireador y flexibles 1/2" >350mm.
Mitigeur lavabo avec aérateur et flexibles de raccordement 1/2" >350mm.

REF.	RRP INC VAT	UOM
61832UK	83.99	PCS
61833UK 	89.99	PCS



MINI MONO BASIN MIXER

Lavabo 65

Mitigeur lavabo 65

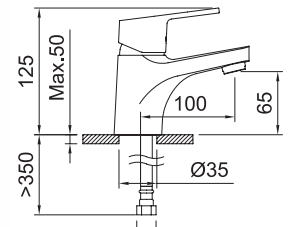

Single-lever basin mixer with aerator and flexible hoses 1/2" >350mm.
Lavabo monomando con aireador y flexibles 1/2" >350mm.
Mitigeur lavabo avec aérateur et flexibles de raccordement 1/2" >350mm.

REF.	RRP INC VAT	UOM
98620UK	71.99	PCS
61748UK 	77.99	PCS



RELATED PRODUCTS

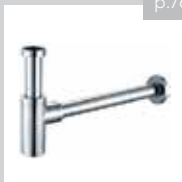

Ref. 96174UK



Ref. 60558UK



Ref. 90755UK

BIDET MIXER

Bide
Mitigeur bidet

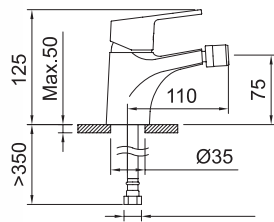

Single-lever bidet mixer with swivel aerator and flexible hoses 1/2" >350mm.
Bidé monomando con aireador a rótula y flexibles 1/2" >350mm.
Mitigeur bidet avec aérateur rotule et flexibles de raccordement 1/2" >350mm.

REF.	RRP INC VAT	UOM
98621UK	71.99	PCS



THERMOSTATIC SHOWER BAR & RAIL KIT

Conjunto de ducha extensible termostático
Colonne de douche extensible thermostatique

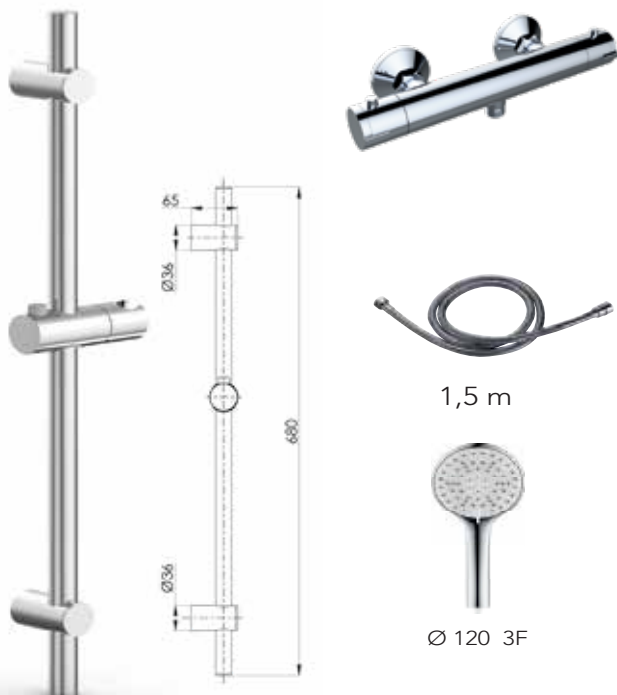

1,5 m



REF.	RRP INC VAT	UOM
62160UK	179.99	PCS



THERMOSTATIC EXTENSIBLE SHOWER SYSTEM

Conjunto de ducha extensible termostático
Colonne de douche extensible thermostatique

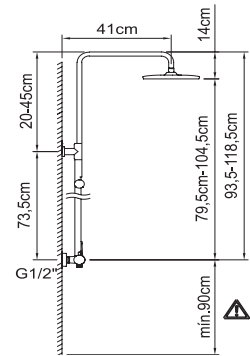
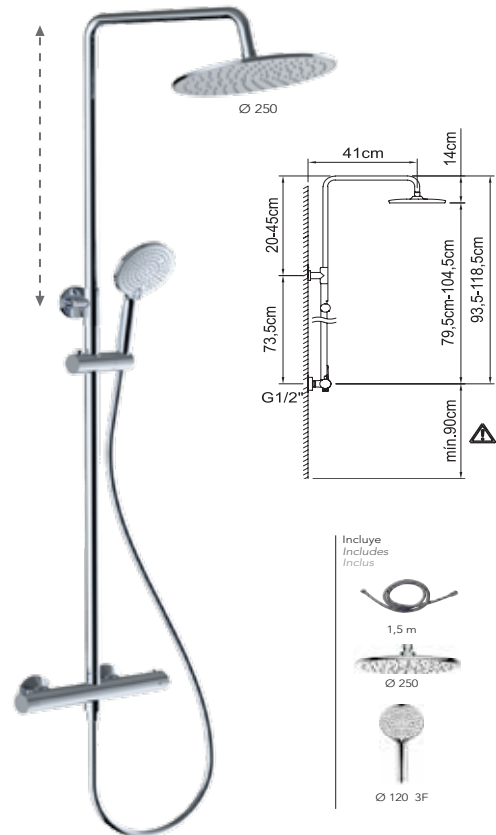

Thermostatic shower set with extendable bar with sliding articulated support.
Conjunto de ducha termostática con barra extensible con soporte articulado deslizante.
Ensemble de douche thermostatique avec barre extensible Box avec support articulé coulissant.

REF.	RRP INC VAT	UOM
62168UK	293.99	PCS



GO! THERMOSTATIC BAR SHOWER MIXER

Ducha termostática
Mitigeur douche thermostatique

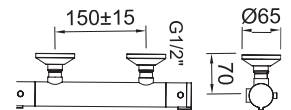
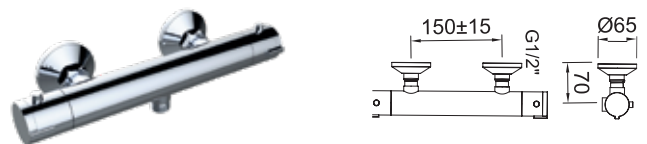

Thermostatic shower mixer.
Ducha termostática.
Mitigeur douche thermostatique.

REF.	RRP INC VAT	UOM
62161UK	131.99	PCS





62131UK
Go2!

MONO BASIN MIXER

Lavabo 100
Mitigeur lavabo 100

MINI MONO BASIN MIXER

Lavabo 65
Mitigeur lavabo 65

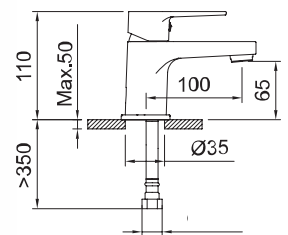
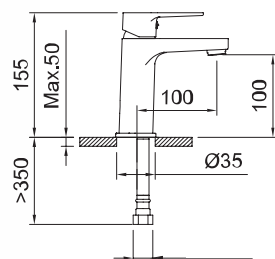

Single-lever basin mixer with aerator and flexible hoses 1/2" >350mm.
Lavabo monomando con aireador y flexibles 1/2" >350mm.
Mitigeur lavabo avec aérateur et flexibles de raccordement 1/2" >350mm.

Single-lever basin mixer with aerator and flexible hoses 1/2" >350mm.
Lavabo monomando con aireador y flexibles 1/2" >350mm.
Mitigeur lavabo avec aérateur et flexibles de raccordement 1/2" >350mm.

REF.	RRP INC VAT	UOM
62131UK	83.99	PCS

REF.	RRP INC VAT	UOM
62130UK	71.99	PCS



GO! THERMOSTATIC BAR SHOWER MIXER
 Ducha termostática
 Mitigeur douche thermostatique



Thermostatic shower mixer.
 Ducha termostática.
 Mitigeur douche thermostatique.

REF.	RRP INC VAT	UOM
62160UK 	179.99	PCS
62161UK	131.99	PCS



BIDET MIXER
 Bide 65
 Mitigeur bidet 65



Single-lever bidet mixer with swivel aerator and flexible hoses 1/2" >350mm.
 Bidé monomando con aireador a rótula y flexibles 1/2" >350mm.
 Mitigeur bidet avec aérateur rotule et flexibles de raccordement 1/2" >350mm.

REF.	RRP INC VAT	UOM
62132UK	71.99	PCS



GO! THERMOSTATIC EXTENSIBLE SHOWER SYSTEM
 Conjunto de ducha extensible termostático

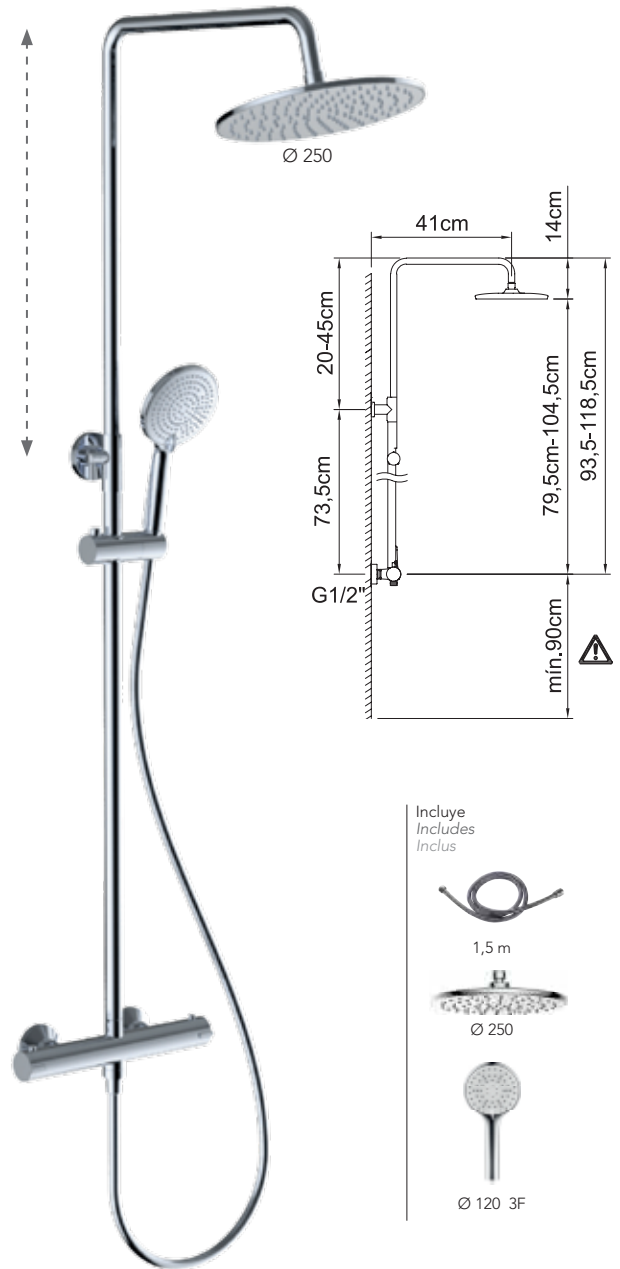

Thermostatic shower set with extendable bar with sliding articulated support.
 Conjunto de ducha termostática con barra extensible con soporte articulado deslizante.
 Ensemble de douche thermostatique avec barre extensible Box avec support articulé coulissant.

REF.	RRP INC VAT	UOM
62168UK	293.99	PCS



MONO BASIN MIXER

Lavabo 100
Mitigeur lavabo 100

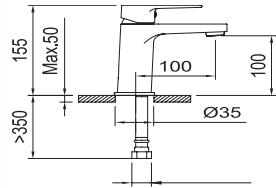

Single-lever basin mixer with aerator and flexible hoses 1/2" >350mm.
Lavabo monomando con aireador y flexibles 1/2" >350mm.
Mitigeur lavabo avec aérateur et flexibles de raccordement 1/2" >350mm.

REF.	RRP INC VAT	UOM
62141UK	89.99	PCS



BLACK

MINI MONO BASIN MIXER

Lavabo 65
Mitigeur lavabo 65

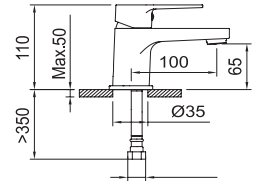

Single-lever basin mixer with aerator and flexible hoses 1/2" >350mm.
Lavabo monomando con aireador y flexibles 1/2" >350mm.
Mitigeur lavabo avec aérateur et flexibles de raccordement 1/2" >350mm.

REF.	RRP INC VAT	UOM
62140UK	77.99	PCS



BLACK

BASIN TAP PAIR

Grifo para lavabo
Robito de lavabo



COMING SOON

REF.	RRP INC VAT	UOM
TBC	TBC	PCS

BATH TAP PAIR

Grifo de baño
Robinet de bain

PCS



COMING SOON

REF.	RRP INC VAT	UOM
TBC	TBC	PCS

BATH SHOWER MIXER

Mezclador de la ducha
Mitigeur de douche



COMING SOON

REF.	RRP INC VAT	UOM
TBC	TBC	PCS

BATH FILLER

Ducha del baño
Bain douche



COMING SOON

REF.	RRP INC VAT	UOM
TBC	TBC	PCS

BIDET MIXER

Bide 65

Mitigeur bidet 65

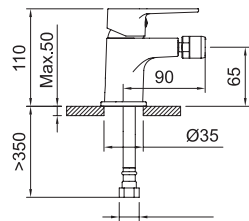

Single-lever bidet mixer with swivel aerator and flexible hoses 1/2" >350mm.
 Bidé monomando con aireador a rótula y flexibles 1/2" >350mm.
 Mitigeur bidet avec aérateur rotule et flexibles de raccordement 1/2" >350mm.

REF.	RRP INC VAT	UOM
62142UK	77.99	PCS



THERMOSTATIC SHOWER BAR & RAIL KIT

Conjunto de ducha extensible termostático

Colonne de douche extensible thermostatique



1,5 m

3F

REF.	RRP INC VAT	UOM
62162UK	209.99	PCS



THERMOSTATIC EXTENSIBLE SHOWER SYSTEM

Conjunto de ducha extensible termostático

Colonne de douche extensible thermostatique

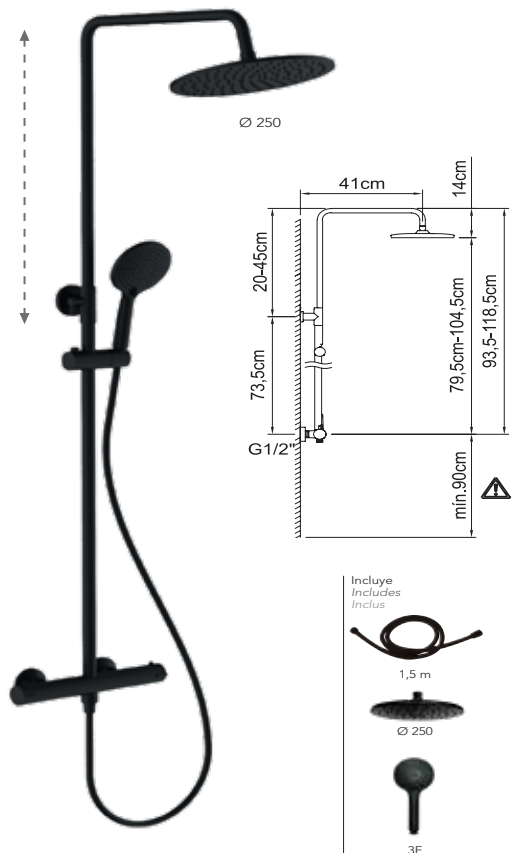

Ø 250

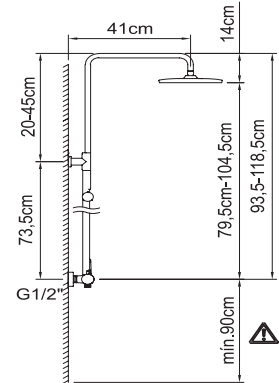

Thermostatic shower set with extensible bar with sliding articulated support.
 Conjunto de ducha termostática con barra extensible con soporte articulado deslizante.
 Ensemble de douche thermostatique avec barre extensible Box avec support articulé coulissant.

REF.	RRP INC VAT	UOM
62169UK	323.99	PCS



THERMOSTATIC BAR SHOWER MIXER

DUCHA TERMOSTÁTICA

Mitigeur douche thermostatique

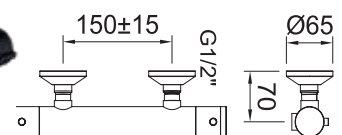
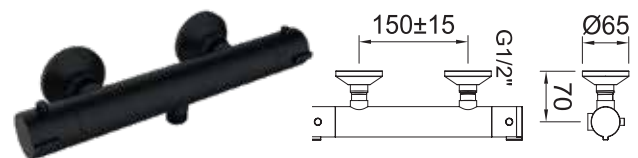

Thermostatic shower mixer.
 Ducha termostática.
 Mitigeur douche thermostatique.

REF.	RRP INC VAT	UOM
62163UK	161.99	PCS





62057UK
Rocket

TALL MONO BASIN MIXER

Lavabo 235

Mitigeur lavabo 235

MONO BASIN MIXER

Lavabo 110

Mitigeur lavabo 110

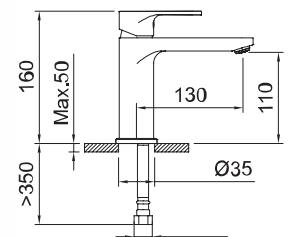
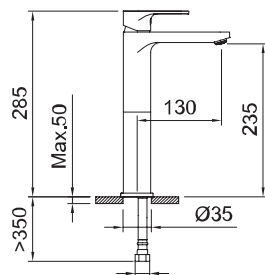

Single-lever basin mixer with aerator and flexible hoses 1/2" >350mm.
Lavabo monomando con aireador y flexibles 1/2" >350mm.
Mitigeur lavabo avec aérateur et flexibles de raccordement 1/2" >350mm.

Single-lever basin mixer with aerator and flexible hoses 1/2" >350mm.
Lavabo monomando con aireador y flexibles 1/2" >350mm.
Mitigeur lavabo avec aérateur et flexibles de raccordement 1/2" >350mm.

REF.	Water Label	RRP INC VAT	UOM
62059UK	5 l/min	119.99	PCS

REF.	Water Label	RRP INC VAT	UOM
62057UK	5 l/min	89.99	PCS

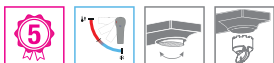



BIDET MIXER
Bide 70
Mitigeur bidet 70

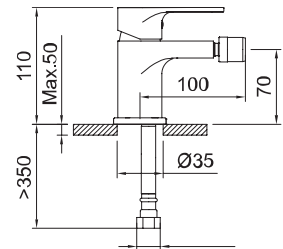

Single-lever bidet mixer with swivel aerator and flexible hoses 1/2" >350mm.
Bidé monomando con aireador a rótula y flexibles 1/2" >350mm.
Mitigeur bidet avec aérateur rotule et flexibles de raccordement 1/2" >350mm.

REF.	Water Label	RRP INC VAT	UOM
62063UK	5 l/min	77.99	PCS



MINI MONO BASIN MIXER
Lavabo 85
Mitigeur lavabo 85

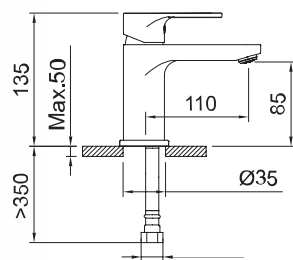

Single-lever basin mixer with aerator and flexible hoses 1/2" >350mm.
Lavabo monomando con aireador y flexibles 1/2" >350mm.
Mitigeur lavabo avec aérateur et flexibles de raccordement 1/2" >350mm.

REF.	Water Label	RRP INC VAT	UOM
62055UK	5 l/min	77.99	PCS



MONO BASIN MIXER SWAN
Lavabo 180
Mitigeur lavabo 180

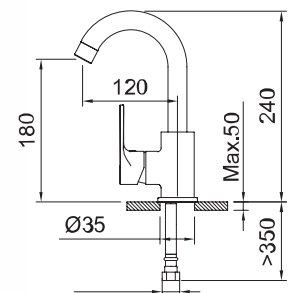

Single-lever basin mixer with aerator and flexible hoses 1/2" >350mm.
Lavabo monomando con aireador y flexibles 1/2" >350mm.
Mitigeur lavabo avec aérateur et flexibles de raccordement 1/2" >350mm.

REF.	Water Label	RRP INC VAT	UOM
62061UK	5 l/min	89.99	PCS



Rocket



TALL MONO BASIN MIXER

Lavabo 235

Mitigeur lavabo 235

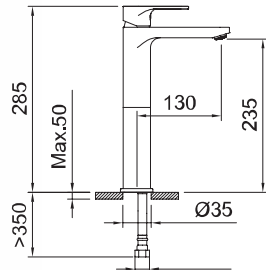

Single-lever basin mixer with aerator and flexible hoses 1/2" >350mm.
Lavabo monomando con aireador y flexibles 1/2" >350mm.
Mitigeur lavabo avec aérateur et flexibles de raccordement 1/2" >350mm.

REF.	RRP INC VAT	UOM
62074UK  	125.99	PCS



MONO BASIN MIXER

Lavabo 110

Mitigeur lavabo 110

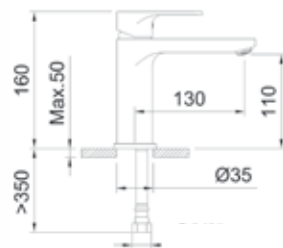

Single-lever basin mixer with aerator and flexible hoses 1/2" >350mm.
Lavabo monomando con aireador y flexibles 1/2" >350mm.
Mitigeur lavabo avec aérateur et flexibles de raccordement 1/2" >350mm.

REF.	RRP INC VAT	UOM
62072UK  	95.99	PCS



BIDET MIXER

Bide 70

Mitigeur bidet 70

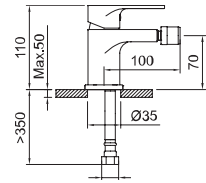

Single-lever bidet mixer with swivel aerator and flexible hoses 1/2" >350mm.
Bidé monomando con aireador a rótula y flexibles 1/2" >350mm.
Mitigeur bidet avec aérateur rotule et flexibles de raccordement 1/2" >350mm.

REF.	RRP INC VAT	UOM
62078UK  	83.99	PCS



BLACK

MONO BASIN MIXER SWAN

Lavabo 180

Mitigeur lavabo 180

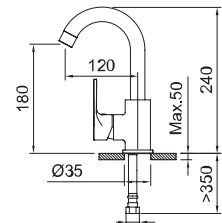

Single-lever basin mixer with aerator and flexible hoses 1/2" >350mm.
Lavabo monomando con aireador y flexibles 1/2" >350mm.
Mitigeur lavabo avec aérateur et flexibles de raccordement 1/2" >350mm.

REF.	RRP INC VAT	UOM
62076UK  	95.99	PCS



BLACK

MINI MONO BASIN MIXER

Lavabo 85

Mitigeur lavabo 85

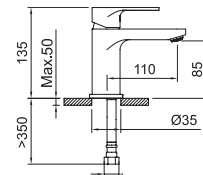

Single-lever basin mixer with aerator and flexible hoses 1/2" >350mm.
Lavabo monomando con aireador y flexibles 1/2" >350mm.
Mitigeur lavabo avec aérateur et flexibles de raccordement 1/2" >350mm.

REF.	RRP INC VAT	UOM
62070UK  	83.99	PCS



BLACK

Araya Mercia Urban

MONO BASIN MIXER

Lavabo
Mitigeur lavabo

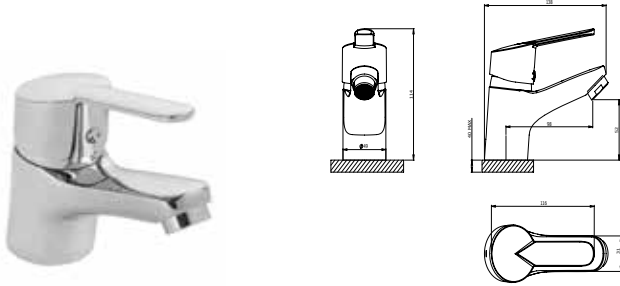

Single-lever basin mixer with aerator and flexible hoses 1/2" >350mm.
Lavabo monomando con aireador y flexibles 1/2" >350mm.
Mitigeur lavabo avec aérateur et flexibles de raccordement 1/2" >350mm.

REF.	RRP INC VAT	UOM
4S1205UK	77.99	PCS



BASIN TAP PAIR

Grifo para lavabo
Roboto de lavabo



REF.	RRP INC VAT	UOM
4S1201UK	77.99	PCS

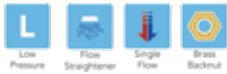

BATH TAP PAIR

Grifo de baño
Robinet de bain



REF.	RRP INC VAT	UOM
4S1202UK	101.99	PCS



BATH FILLER

Ducha del baño
Bain douche



REF.	RRP INC VAT	UOM
4S1203UK	161.99	PCS

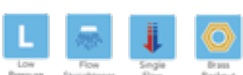

BATH SHOWER MIXER

Mezclador de la ducha
Mitigeur de douche



REF.	RRP INC VAT	UOM
4S1204UK	197.99	PCS

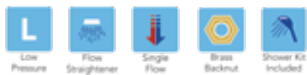

MONO BASIN MIXER

Lavabo
Mitigeur lavabo

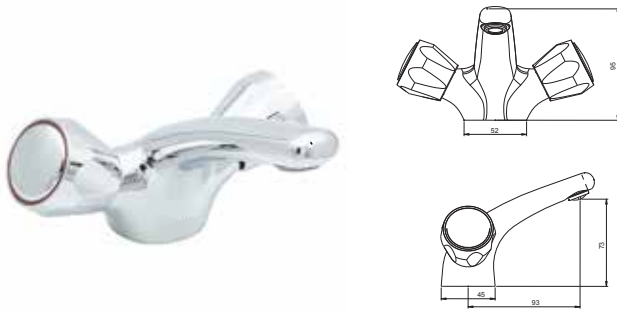

REF.	RRP INC VAT	UOM
922034UK	77.99	PCS



BASIN TAP PAIR

Grifo para lavabo
Robito de lavabo

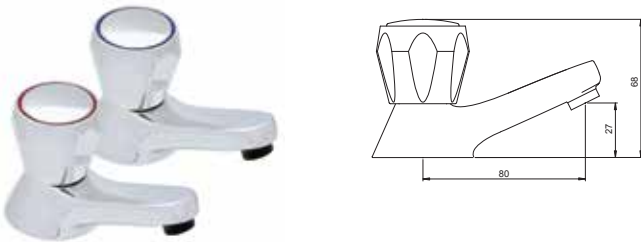

BATH TAP PAIR

Grifo de bano
Robinet de bain



REF.	RRP INC VAT	UOM
922031UK	47.99	PCS



BATH SHOWER MIXER

Mezclador de la ducha
Mitigeur de douche



REF.	RRP INC VAT	UOM
922036UK	149.99	PCS



REF.	RRP INC VAT	UOM
922033UK	59.99	PCS

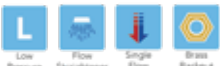

BATH FILLER

Ducha del bano
Bain douche



REF.	RRP INC VAT	UOM
922041UK	125.99	PCS



Araya Mercia QT

MONO BASIN MIXER

Lavabo
Mitigeur lavabo

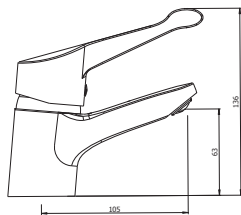

Single-lever basin mixer with flexible hoses 1/2" >350mm.
Lavabo monomando con aireador y flexibles 1/2" >350mm.
Mitigeur lavabo avec aérateur et flexibles de raccordement 1/2" >350mm.

REF.	RRP INC VAT	UOM
922064UK  5.7l/min	77.99	PCS



BASIN TAP PAIR

Grifo para lavabo
Roboto de lavabo

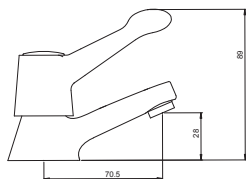

REF.	RRP INC VAT	UOM
922061UK	59.99	PCS



BATH TAP PAIR

Grifo de baño
Robinet de bain

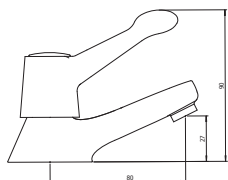

REF.	RRP INC VAT	UOM
922063UK	77.99	PCS



BATH SHOWER MIXER

Mezclador de la ducha
Mitigeur de douche

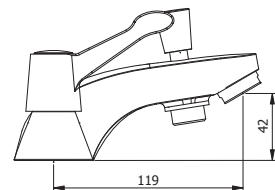
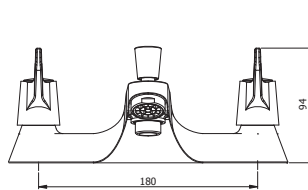

REF.	RRP INC VAT	UOM
922066UK	149.99	PCS



BATH FILLER

Ducha del baño
Bain douche

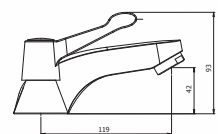
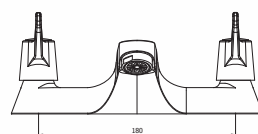

REF.	RRP INC VAT	UOM
922000UK	125.99	PCS



MONO BASIN MIXER

Lavabo
Mitigeur lavabo

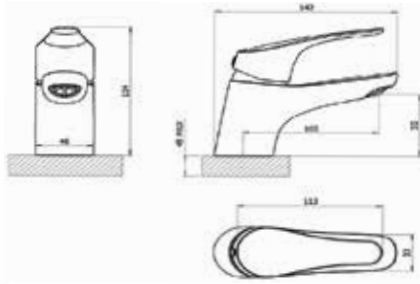

Single-lever basin mixer with flexible hoses 1/2" >350mm.
Lavabo monomando con aireador y flexibles 1/2" >350mm.
Mitigeur lavabo avec aérateur et flexibles de raccordement 1/2" >350mm.

REF.	RRP INC VAT	UOM
922303UK	83.99	PCS



BATH FILLER

Ducha del baño
Bain douche

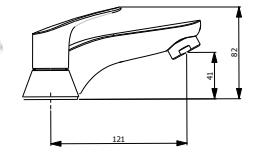
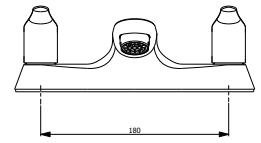

REF.	RRP INC VAT	UOM
922305UK	143.99	PCS



SLIM MONO BASIN MIXER

Lavabo
Mitigeur lavabo

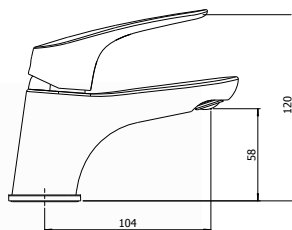

Single-lever basin mixer with flexible hoses 1/2" >350mm.
Lavabo monomando con aireador y flexibles 1/2" >350mm.
Mitigeur lavabo avec aérateur et flexibles de raccordement 1/2" >350mm.

REF.	RRP INC VAT	UOM
922302UK	77.99	PCS



BATH SHOWER MIXER

Lavabo
Mitigeur lavabo

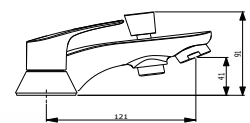
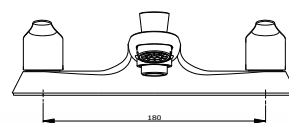

REF.	RRP INC VAT	UOM
922306UK	155.99	PCS



Performa Cross Top

BASIN TAP

Grifo para lavabo
Robito de lavabo



REF.	RRP INC VAT	UOM
301007UK Basin Tap Hot	71.99	PCS
301017UK Basin Tap Cold	71.99	PCS



BATH TAP

Grifo para lavabo
Robito de lavabo

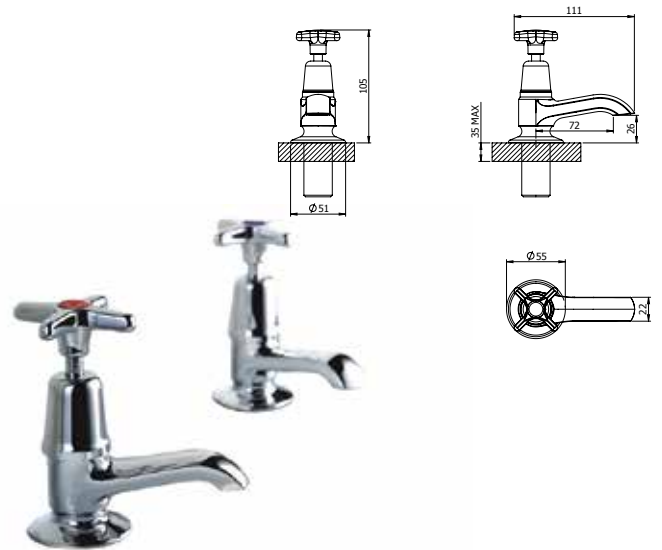

REF.	RRP INC VAT	UOM
302008UK Bath Tap Hot	83.99	PCS
302018UK Bath Tap Cold	83.99	PCS



BASIN TAP PAIR

Grifo para lavabo
Robito de lavabo



REF.	RRP INC VAT	UOM
349001UK Non-convulsive Basin Tap Pair including 2 x hot & cold indices	113.99	PCS



BASIN TAP

Grifo para lavabo
Robito de lavabo

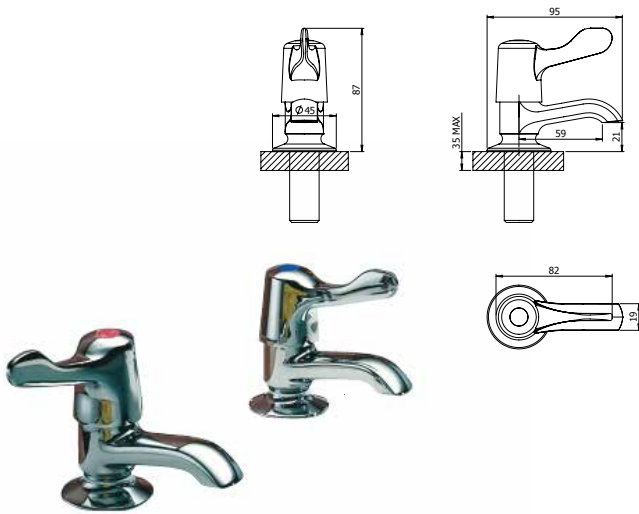

REF.	RRP INC VAT	UOM
308027UK Basin Tap Hot	59.99	PCS
308037UK Basin Tap Cold	59.99	PCS



THERMOSTATIC EXTENDABLE SHOWER SYSTEM

THERMOSTATIC EXTENDABLE SHOWER SYSTEM

CONJUNTO DE DUCHA EXTENSIBLE TERMOSTÁTICO
Colonne de douche extensible thermostatique

UP! **urban**



Thermostatic shower set with extendable bar with sliding articulated support.
Conjunto de ducha termostática con barra extensible con soporte articulado deslizante.
Ensemble de douche thermostatique avec barre extensible avec support articulé coulissant.

REF.	RRP INC VAT	UOM
61003UK  BELG 23/060/27.8	437.99	PCS



THERMOSTATIC EXTENDABLE SHOWER SYSTEM

CONJUNTO DE DUCHA EXTENSIBLE TERMOSTÁTICO
Colonne de douche extensible thermostatique

UP! **urban**

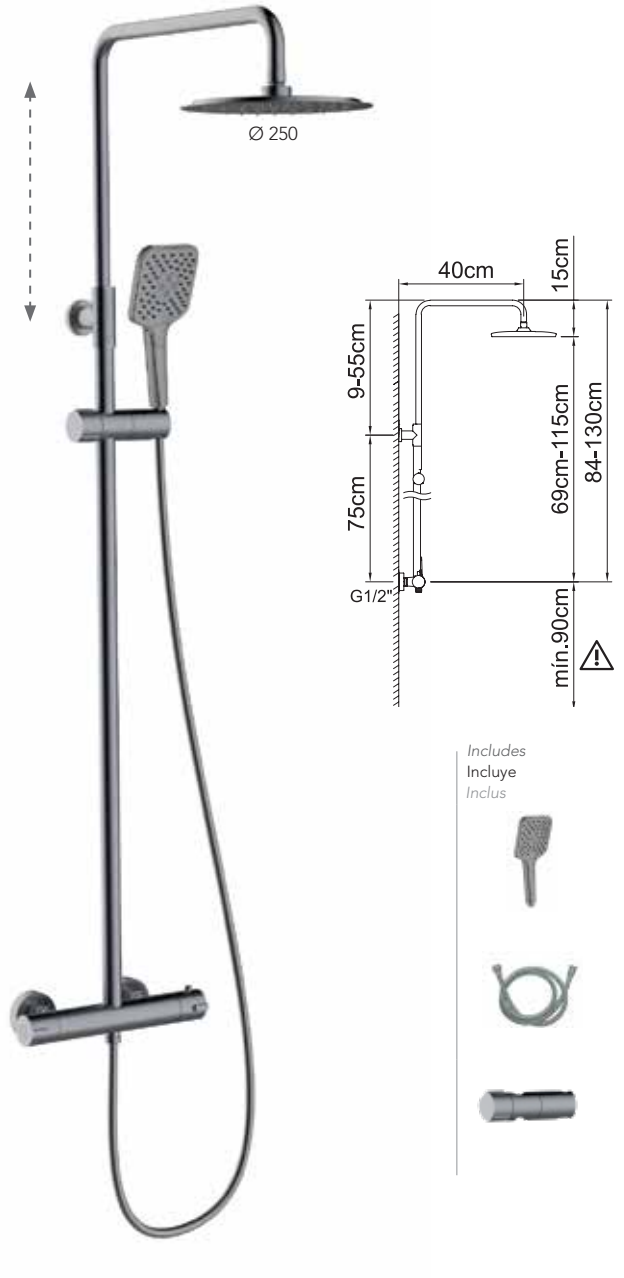

Thermostatic shower set with extendable bar with sliding articulated support.
Conjunto de ducha termostática con barra extensible con soporte articulado deslizante.
Ensemble de douche thermostatique avec barre extensible avec support articulé coulissant.

REF.	RRP INC VAT	UOM
61958UK	647.99	PCS



THERMOSTATIC EXTENDABLE SHOWER SYSTEM

CONJUNTO DE DUCHA EXTENSIBLE TERMOSTÁTICO

Colonne de douche extensible thermostatique

UP! **urban**

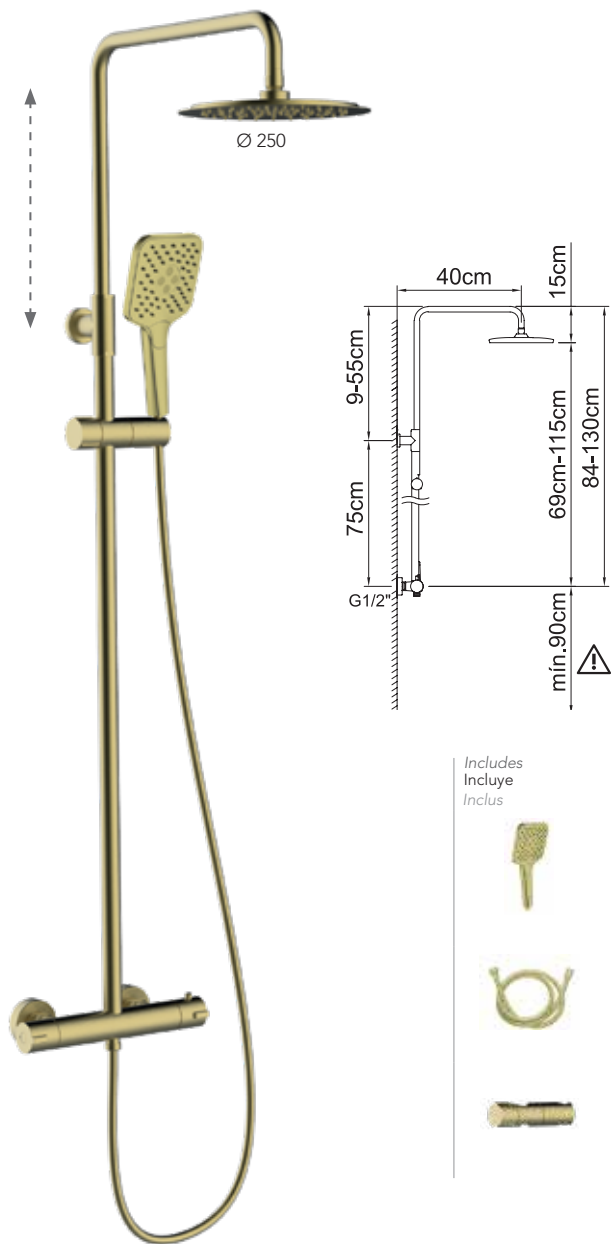

Thermostatic shower set with extendable bar with sliding articulated support.
 Conjunto de ducha termostática con barra extensible con soporte articulado deslizante.
 Ensemble de douche thermostatique avec barre extensible avec support articulé coulissant.

REF.	RRP INC VAT	UOM
61959UK	665.99	PCS

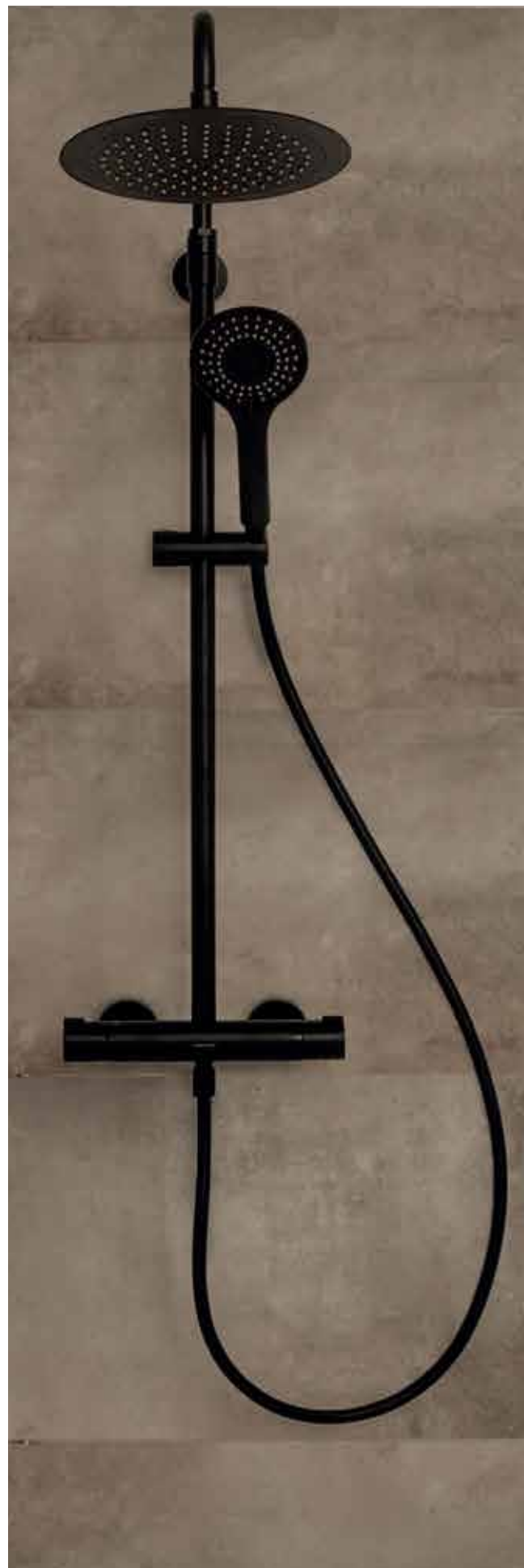

Showers - UP urban

Go!



THERMOSTATIC EXTENDIBLE SHOWER SYSTEM

Conjunto de ducha extensible termostático
Colonne de douche extensible thermostatique

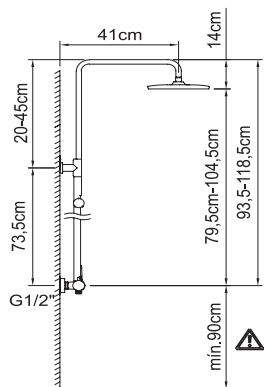

Thermostatic shower set with extendable bar with sliding articulated support.
Conjunto de ducha termostática con barra extensible con soporte articulado deslizante.
Ensemble de douche thermostatique avec barre extensible Box avec support articulé coulissant.

REF.	RRP INC VAT	UOM
62168UK	293.99	PCS



THERMOSTATIC SHOWER BAR & RAIL KIT

Conjunto de ducha extensible termostático
Colonne de douche extensible thermostatique

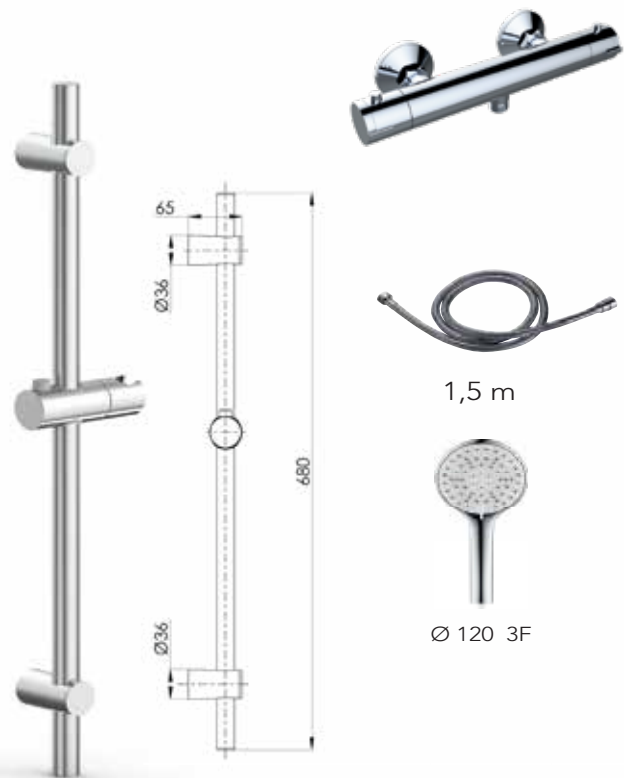

REF.	RRP INC VAT	UOM
62160UK	179.99	PCS



THERMOSTATIC SHOWER MIXER

Ducha termostática
Mitigeur douche thermostatique

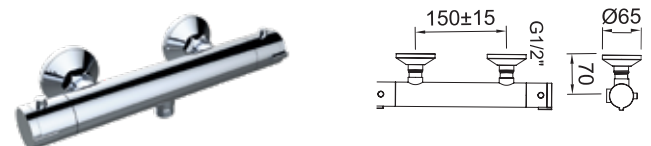

Thermostatic shower mixer.
Ducha termostática.
Mitigeur douche thermostatique.

REF.	RRP INC VAT	UOM
62161UK	131.99	PCS





THERMOSTATIC EXTENDIBLE SHOWER SYSTEM

Conjunto de ducha extensible termostático
Colonne de douche extensible thermostatique

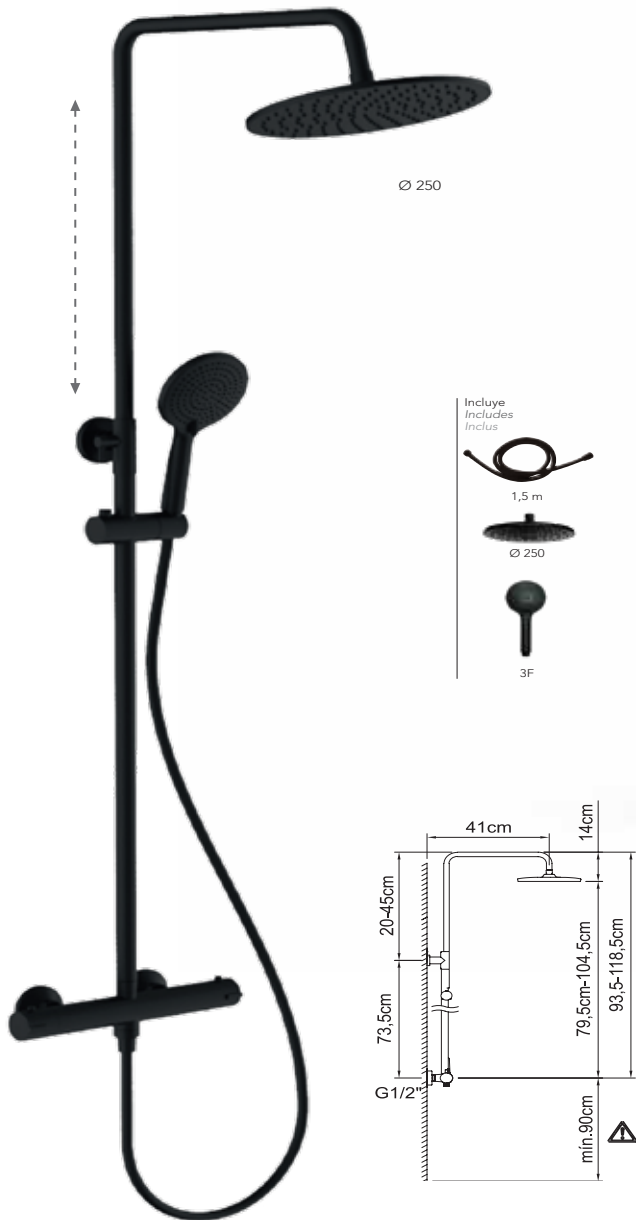

Thermostatic shower set with extendable bar with sliding articulated support.
Conjunto de ducha termostática con barra extensible con soporte articulado deslizante.

Ensemble de douche thermostatique avec barre extensible Box avec support articulé coulissant.

REF.	RRP INC VAT	UOM
62169UK	323.99	PCS



THERMOSTATIC SHOWER BAR & RAIL KIT

Conjunto de ducha extensible termostático
Colonne de douche extensible thermostatique

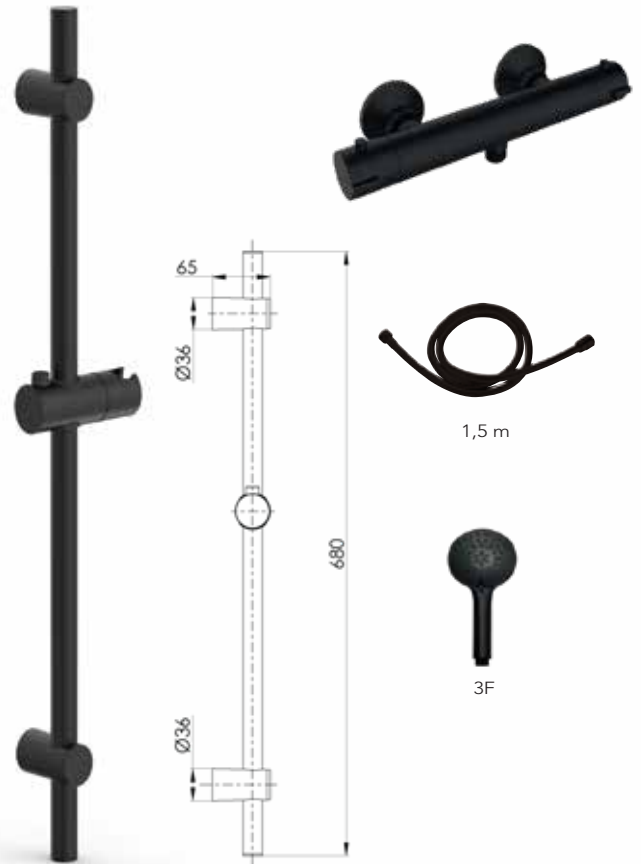

REF.	RRP INC VAT	UOM
62162UK	209.99	PCS



THERMOSTATIC SHOWER MIXER

DUCHA TERMOSTÁTICA
Mitigeur douche thermostatique

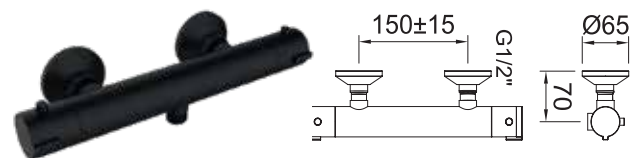

Thermostatic shower mixer.

Ducha termostática.

Mitigeur douche thermostatique.

REF.	RRP INC VAT	UOM
62163UK	161.99	PCS





THERMOSTATIC SHOWER BAR & RAIL KIT

Conjunto de ducha extensible termostático
Colonne de douche extensible thermostatique

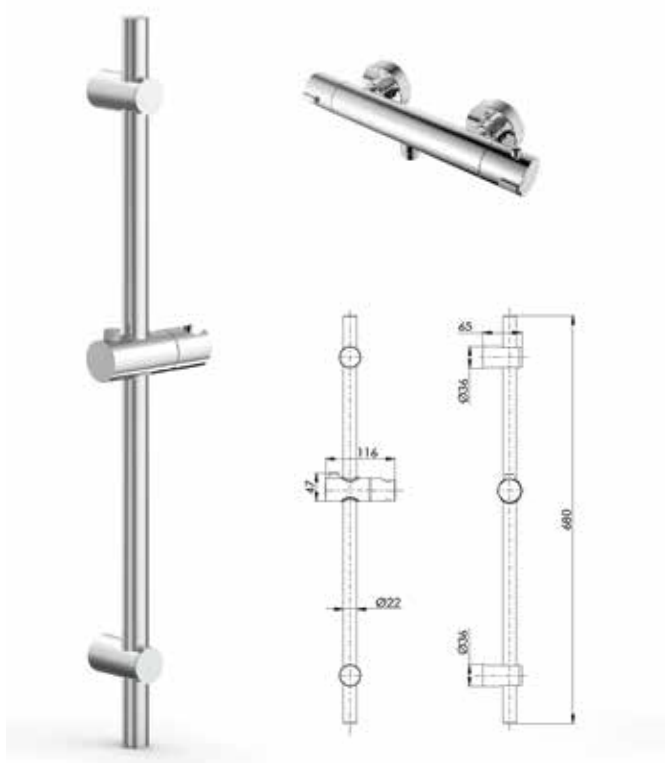

Thermostatic shower set with extendable bar with sliding articulated support.
Conjunto de ducha termostática con barra extensible con soporte articulado deslizable.

Ensemble de douche thermostatique avec barre extensible Box avec support articulé coulissant.

REF.	RRP INC VAT	UOM
923042UK 	131.99	PCS



THERMOSTATIC SHOWER BAR

DUCHA TERMOSTÁTICA
Mitigeur douche thermostatique



Thermostatic shower mixer.
Ducha termostática.
Mitigeur douche thermostatique.

REF.	RRP INC VAT	UOM
923040UK	83.99	PCS



THERMOSTATIC SHOWER BAR & RAIL KIT

Conjunto de ducha extensible termostático
Colonne de douche extensible thermostatique

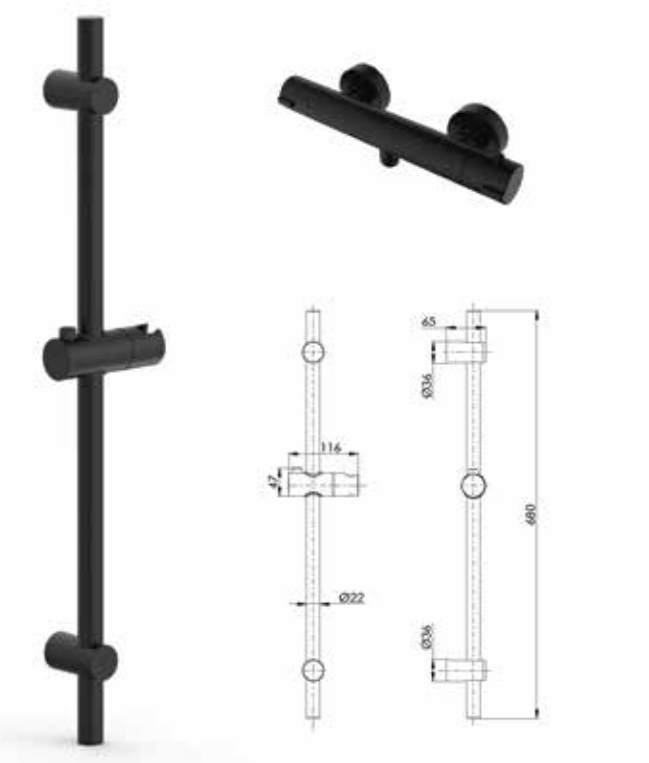

Thermostatic shower set with extendable bar with sliding articulated support.
Conjunto de ducha termostática con barra extensible con soporte articulado deslizable.

Ensemble de douche thermostatique avec barre extensible Box avec support articulé coulissant.

REF.	RRP INC VAT	UOM
923043UK 	143.99	PCS



THERMOSTATIC SHOWER BAR

DUCHA TERMOSTÁTICA
Mitigeur douche thermostatique



Thermostatic shower mixer.
Ducha termostática.
Mitigeur douche thermostatique.

REF.	RRP INC VAT	UOM
923041UK	95.99	PCS



Hygienic shower - Shattaf

Ducha higiénical Douche hygiénique



SHATTAF TUAREG

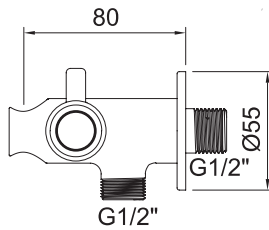

Wall mounted bidet with support included.
 Ducha higiénica mural con soporte integrado.
 Ensemble douchette WC eau froide avec sortie réservoir de chasse d'eau.

Ref. 98442UK

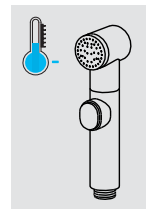
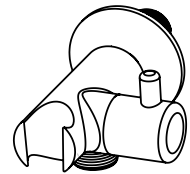

REF.	RRP INC VAT	UOM
98442UK	65.99	PCS





SHATTAF TOUAREG Ref. 97801

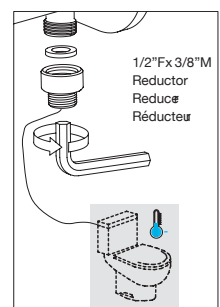
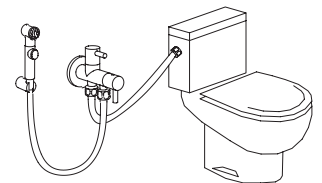
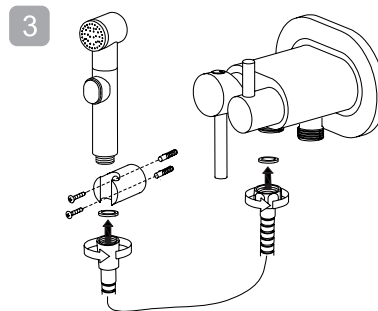
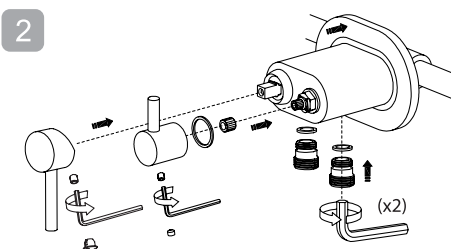
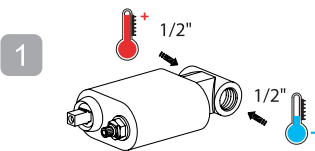

Hygienic shower - Shattaf

Ducha higiénica / Douche hygiénique

SHATTAF TOUBKAL

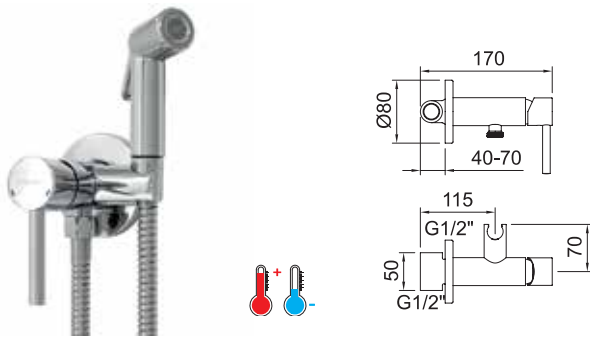

Wall mounted single mixer.
Ducha higiénica monomando empotrar.
Ensemble douchette WC hygiénique avec sortie réservoir de chasse d'eau.

REF.	RRP INC VAT	UOM
61117UK 	125.99	PCS



SHATTAF TOUBKAL

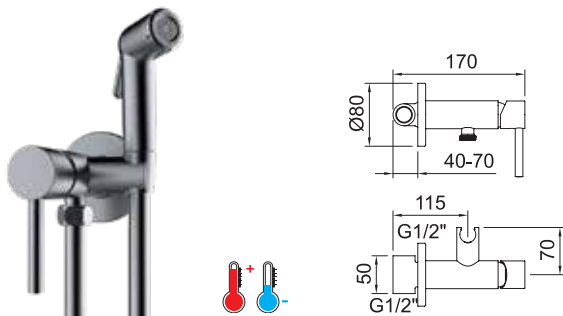

Wall mounted single mixer shattaf.
Ducha higiénica monomando empotrar.
Ensemble douchette WC hygiénique avec sortie réservoir de chasse d'eau.

REF.	RRP INC VAT	UOM
61974UK 	185.99	PCS



SHATTAF TOUBKAL

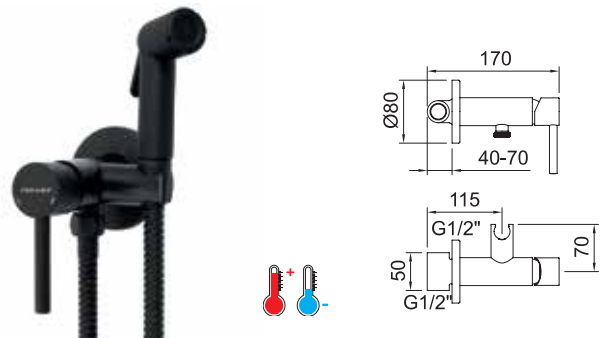

Wall mounted single mixer.
Ducha higiénica monomando empotrar.
Ensemble douchette WC hygiénique avec sortie réservoir de chasse d'eau.

REF.	RRP INC VAT	UOM
61118UK 	137.99	PCS



SHATTAF TOUBKAL

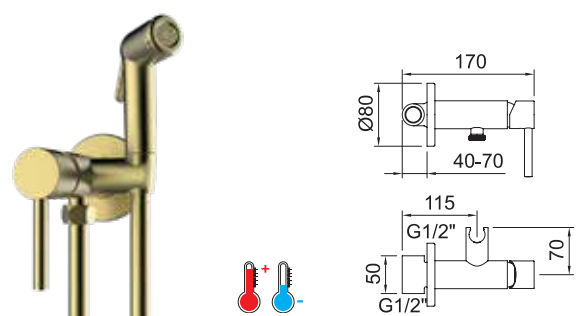

Wall mounted single mixer shattaf.
Ducha higiénica monomando empotrar.
Ensemble douchette WC hygiénique avec sortie réservoir de chasse d'eau.

REF.	RRP INC VAT	UOM
61975UK 	173.99	PCS

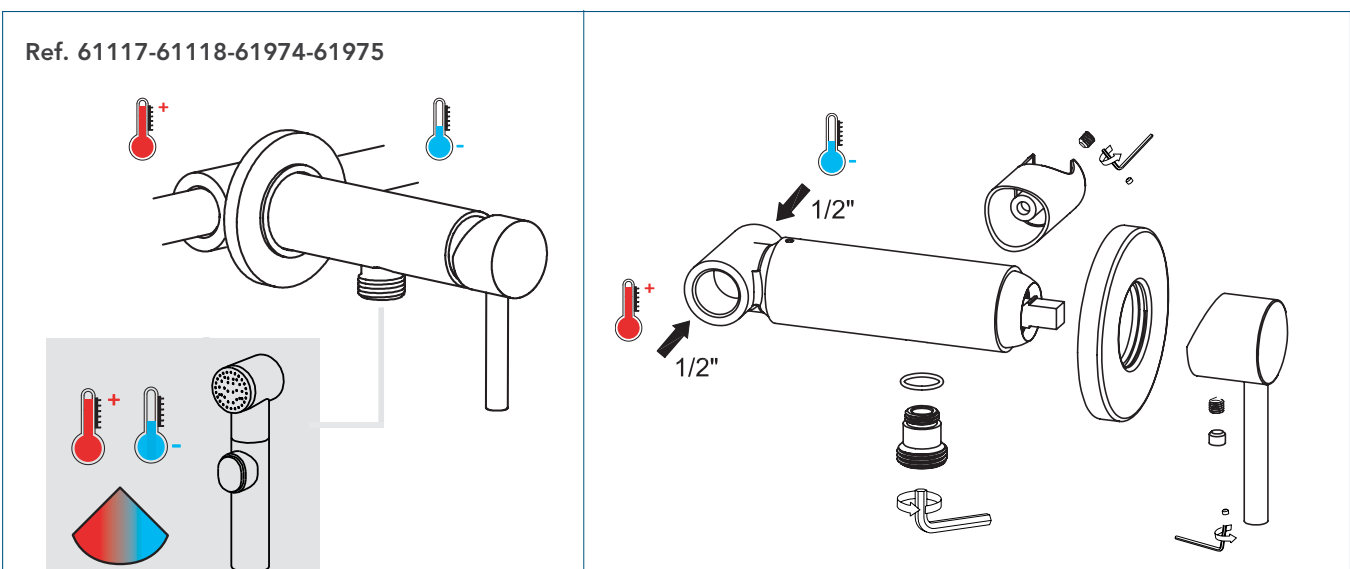

Sliding Bar Sets

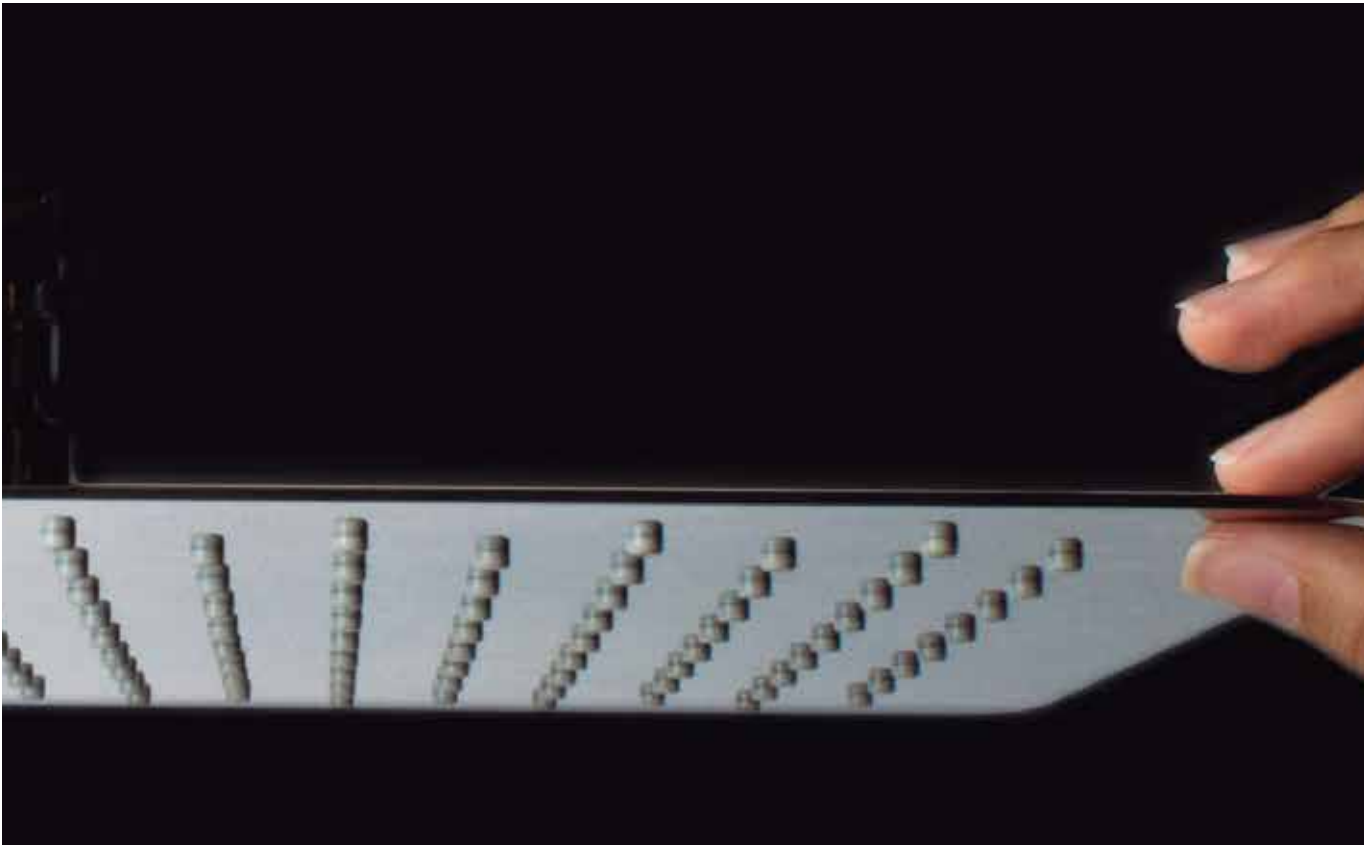

SLIDING BAR SET
 CONJUNTO BARRA DUCHA
 Ensemble barre de douche

SLIDING BAR
 BARRA DUCHA
 Barre de douche

SYVARI

SYVARI BLACK

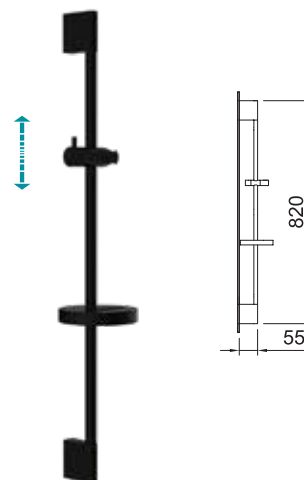

SHOWER SET WITH Ø20X820MM BAR WITH SLIDING ARTICULATED SUPPORT.
 Conjunto de ducha con barra Ø20x820mm con soporte articulado deslizante.
 Ensemble de douche avec barre Ø20x820mm avec support articulé coulissant.

SHOWER BAR SET Ø20X820MM.
 Conjunto barra de ducha Ø20x820mm.
 Ensemble de barre de douche Ø20x820mm.

REF.	RRP INC VAT	UOM
98886UK ¹  	65.99	PCS

REF.	RRP INC VAT	UOM
61933UK	41.99	PCS



Shower Heads

SLIDING BAR SET

CONJUNTO BARRA DUCHA
Ensemble barre de douche

CITY AIR



CITY AIR SHOWER BAR SET.

Conjunto barra de ducha City Air.
Ensemble de barre de douche City Air.

REF.	RRP INC VAT	UOM
99624UK  Ø19x700mm	65.99	PCS

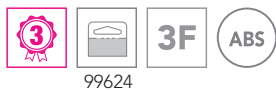

SLIDING BAR SET

CONJUNTO BARRA DUCHA
Ensemble barre de douche

STYLE



STYLE SHOWER BAR SET Ø19X700MM.

Conjunto barra de ducha Style Ø19x700mm.
Ensemble de barre de douche Style Ø19x700mm.

REF.	RRP INC VAT	UOM
99627UK  Ø19x700mm	83.99	PCS



SHOWER HEAD

ROCIADOR DUCHA
Douche de tête

UP! urban SLIM



UP! URBAN SLIM HEAD SHOWER Ø250MM.

Rociador ducha Up! Urban Slim Ø250mm.
Douche de tête Up! Urban Slim Ø250mm.

REF.	RRP INC VAT	UOM
61047UK	53.99	PCS



SHOWER HEAD

ROCIADOR DUCHA
Douche de tête

UP! urban SLIM



UP! URBAN SLIM HEAD SHOWER Ø250MM.

Rociador ducha Up! Urban Slim Ø250mm.
Douche de tête Up! Urban Slim Ø250mm.

REF.	RRP INC VAT	UOM
61046UK	47.99	PCS



SHOWER HEAD

ROCIADOR DUCHA
Douche de tête

HEXAGON AIR

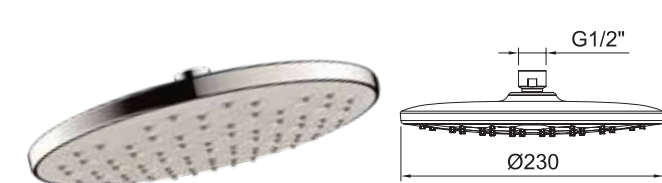

HEXAGON AIR HEAD SHOWER Ø230MM.

Rociador ducha Hexagon Air Ø230mm.
Douche de tête Hexagon Air Ø230mm.

REF.	RRP INC VAT	UOM
60306UK	41.99	PCS



Shower Head Handsets

TechAIR



CLEVER HANDSETS USE THE ADVANCED TECHNOLOGY AIR ADVANCED. MIXING AIR WITH THE INCOMING WATER REDUCES THE WATER CONSUMPTION AT LEAST 30%.

Los teléfonos de ducha Clever usan la tecnología AIR Advanced.

Injectando aire antes de la salida del agua, se consigue dar volumen a las gotas obteniendo una sensación más suave y confortable en la ducha.

Les douchettes Clever sont équipées de la technologie AIR Advanced la plus avancée. L'injection d'air avant la sortie d'eau permet de donner du volume aux gouttes, et d'obtenir une sensation plus douce et confortable sous la douche.



HANDSET
Ducha
Douchette

HEXAGON AIR



Hexagon Air shower handset Ø100mm.
Teléfono ducha Hexagon Air Ø100mm.
Douchette Hexagon Air Ø100mm.

REF.	RRP INC VAT	UOM
60307UK	35.99	PCS



HANDSET
Ducha
Douchette

BEAM



Beam shower handset Ø120mm.
Teléfono ducha Beam Ø120mm.
Douchette Beam Ø120mm.

REF.	RRP INC VAT	UOM
60304UK ¹	35.99	PCS



¹ High pressure outlet with spray water sensation. Con salida de agua a alta presión vaporizada. Avec sortie d'eau à haute pression vaporisée.

Funciones
Fonctions

Example of 5 functions handset

Ejemplo de teléfono ducha 5 funciones Exemple de douchette 5 jets

5F - Tanganyka (Ref.97994)



Foam /
Espuma Mousse



Rain /
Lluvia Pluie



Massage /
Masaje Massage



Fog /
Niebla Brume



Spray /
Spray Spray

HANDSET
Ducha
Douchette

UP! urban



Up! Urban shower handset Ø110mm.
Teléfono ducha Up! Urban Ø110mm.
Douchette Up! Urban Ø110mm.

REF.	RRP INC VAT	UOM
61043UK	29.99	PCS



HANDSET
Ducha
Douchette

UP! urban



Up! Urban shower handset Ø80mm.
Teléfono ducha Up! Urban Ø80mm.
Douchette Up! Urban Ø80mm.

REF.	RRP INC VAT	UOM
61045UK	11.99	PCS



AUTOCLEAN ABS SHOWER HEAD
Autoclean shower head
Douche de tête autonettoyante

AUTOCLEAN



Rociador ducha autolimpiable Ø230mm.
Autoclean head shower Ø230mm.
Douche de tête autonettoyante Ø230mm.

REF.	RRP INC VAT	UOM
60305UK	71.99	PCS



HANDSET
Ducha
Douchette

UP! urban



Up! Urban shower handset Ø110mm.
Teléfono ducha Up! Urban Ø110mm.
Douchette Up! Urban Ø110mm.

REF.	RRP INC VAT	UOM
61044UK	29.99	PCS



HANDSET
Ducha
Douchette

UP! urban



Up! Urban shower handset Ø80mm.
Teléfono ducha Up! Urban Ø80mm.
Douchette Up! Urban Ø80mm.

REF.	RRP INC VAT	UOM
61874UK	14.39	PCS



Shower Hoses

HOSE
Flexo ducha
Flexible

BLACK HOSE

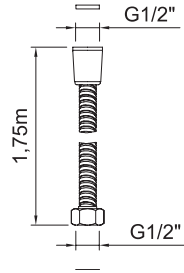

Hose. 1,75m
Flexo de ducha. 1,75m
Flexible. 1,75m

REF.	RRP INC VAT	UOM
60795UK	35.99	PCS



HOSE
Flexo ducha
Flexible

SILVER HOSE MAR

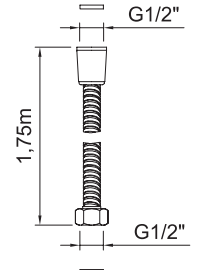

Hose. 1,75m
Flexo de ducha. 1,75m
Flexible. 1,75m

REF.	RRP INC VAT	UOM
61147UK  	23.99	PCS



HOSE
Flexo ducha
Flexible

HOSE

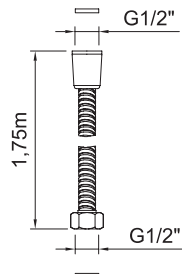

Hose. 1,75m
Flexo de ducha. 1,75m
Flexible. 1,75m

REF.	RRP INC VAT	UOM
61972UK	35.99	PCS



HOSE
Flexo ducha
Flexible

HOSE

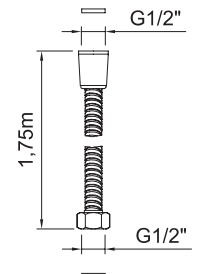

Hose. 1,75m
Flexo de ducha. 1,75m
Flexible. 1,75m

REF.	RRP INC VAT	UOM
61973UK	35.99	PCS



HOSE
Flexo ducha
Flexible



Hose. 1,5m
Flexo de ducha. 1,5m
Flexible. 1,5m

REF.	RRP INC VAT	UOM
62232UK	17.99	PCS



HOSE
Flexo ducha
Flexible

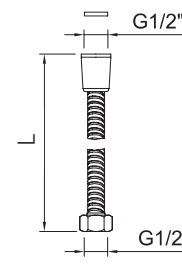

Hose.
Flexo de ducha.
Flexible.

REF.	RRP INC VAT	UOM
60628UK  L=1,75m	15.59	PCS



Bottle Traps

BRASS BOTTLE TRAP

SIFÓN BOTELLA LATÓN / Siphon laiton

elegance

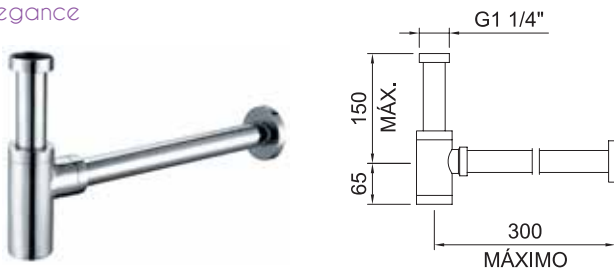

Bottle trap 1 1/4" with tube Ø32mm.
Sifón de botella 1 1/4" con tubo de Ø32mm.
Siphon bouteille 1 1/4" avec tube Ø32mm.

REF.	RRP INC VAT	UOM
96174UK	53.99	PCS



BRASS BOTTLE TRAP

SIFÓN BOTELLA LATÓN / Siphon laiton

elegance

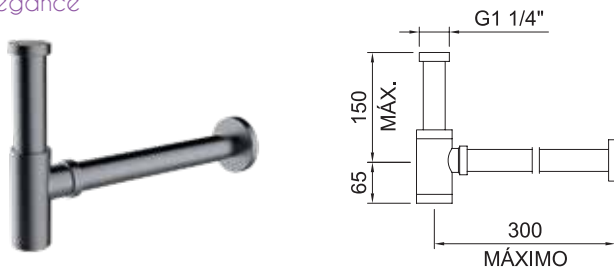

Bottle trap 1 1/4" with tube Ø32mm.
Sifón de botella 1 1/4" con tubo de Ø32mm.
Siphon bouteille 1 1/4" avec tube Ø32mm.

REF.	RRP INC VAT	UOM
61976UK	65.99	PCS



BRASS BOTTLE TRAP

SIFÓN BOTELLA LATÓN / Siphon laiton

elegance

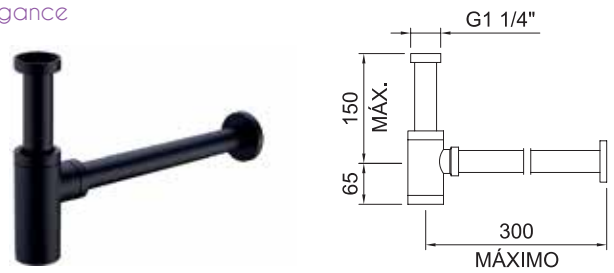

Bottle trap 1 1/4" with tube Ø32mm.
Sifón de botella 1 1/4" con tubo de Ø32mm.
Siphon bouteille 1 1/4" avec tube Ø32mm.

REF.	RRP INC VAT	UOM
61122UK	59.99	PCS



BRASS BOTTLE TRAP

SIFÓN BOTELLA LATÓN / Siphon laiton

elegance

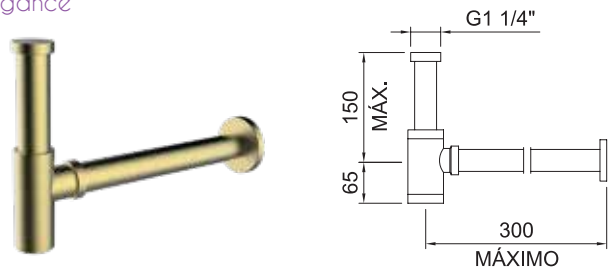

Bottle trap 1 1/4" with tube Ø32mm.
Sifón de botella 1 1/4" con tubo de Ø32mm.
Siphon bouteille 1 1/4" avec tube Ø32mm.

REF.	RRP INC VAT	UOM
61977UK	65.99	PCS



BRASS BOTTLE TRAP

SIFÓN BOTELLA LATÓN / Siphon laiton

urban

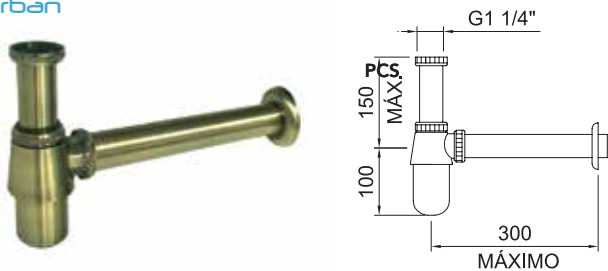

Bottle trap 1 1/4" with tube Ø32mm.
Sifón de botella 1 1/4" con tubo de Ø32mm.
Siphon bouteille 1 1/4" avec tube Ø32mm.



REF.	RRP INC VAT	UOM
61820UK	41.99	PCS

BRASS BOTTLE TRAP

SIFÓN BOTELLA LATÓN / Siphon laiton

urban

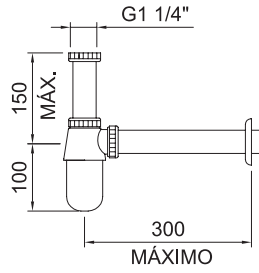

Bottle trap 1 1/4" with tube Ø32mm.
Sifón de botella 1 1/4" con tubo de Ø32mm.
Siphon bouteille 1 1/4" avec tube Ø32mm.

REF.	RRP INC VAT	UOM
90755UK	29.99	PCS



BRASS BOTTLE TRAP

SIFÓN BOTELLA LATÓN / Siphon laiton

urban

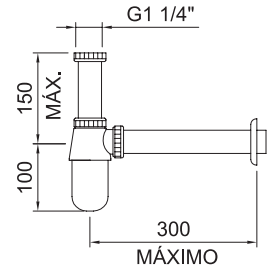

Bottle trap 1 1/4" with tube Ø32mm.
Sifón de botella 1 1/4" con tubo de Ø32mm.
Siphon bouteille 1 1/4" avec tube Ø32mm.

REF.	RRP INC VAT	UOM
62049UK	41.99	PCS



BLACK



PRODUCTO
SOLUCIÓN

Click Wastes

BASIN CLICK WASTE

VÁLVULA DESAGÜE SISTEMA QUICK-CLAC / Vidage quick-clac

LEO

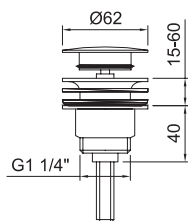

604181

Pop-up quick-clac 1 1/4\"

Válvula desagüe universal sistema quick-clac 1 1/4\"

Vidage universel quick-clac 1 1/4\"

REF.	RRP INC VAT	UOM
98674UK	26.39	PCS



Metálico
Metallic · Métallique



BASIN CLICK WASTE

VÁLVULA DESAGÜE SISTEMA QUICK-CLAC / Vidage quick-clac

LEO

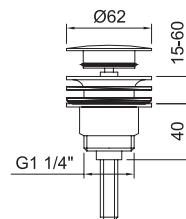

Pop-up quick-clac 1 1/4\"

Válvula desagüe universal sistema quick-clac 1 1/4\"

Vidage universel quick-clac 1 1/4\"

REF.	RRP INC VAT	UOM
60702UK	32.39	PCS



Metálico
Metallic · Métallique

BLACK



BASIN CLICK WASTE

VÁLVULA DESAGÜE SISTEMA QUICK-CLAC / Vidage quick-clac

LEO

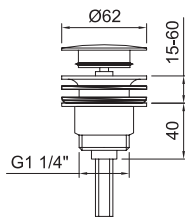

Pop-up quick-clac 1 1/4\"

Válvula desagüe universal sistema quick-clac 1 1/4\"

Vidage universel quick-clac 1 1/4\"

REF.	RRP INC VAT	UOM
60558UK	19.19	PCS



Sintético
Synthetic · Synthétique



BASIN CLICK WASTE

VÁLVULA DESAGÜE SISTEMA QUICK-CLAC / Vidage quick-clac

LEO

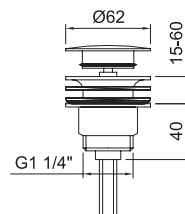

Pop-up quick-clac 1 1/4\"

Válvula desagüe universal sistema quick-clac 1 1/4\"

Vidage universel quick-clac 1 1/4\"

REF.	RRP INC VAT	UOM
61978UK	32.39	PCS



Metálico
Metallic · Métallique

BRUSHED GUN METAL PVD



BASIN CLICK WASTE

VÁLVULA DESAGÜE SISTEMA QUICK-CLAC / Vidage quick-clac

LEO

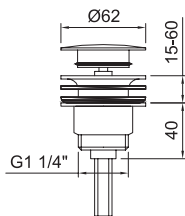

Pop-up quick-clac 1 1/4\"

Válvula desagüe universal sistema quick-clac 1 1/4\"

Vidage universel quick-clac 1 1/4\"

REF.	RRP INC VAT	UOM
61979UK	32.39	PCS



Metálico
Metallic · Métallique

BRUSHED GOLD PVD



BASIN CLICK WASTE

VÁLVULA DESAGÜE SISTEMA QUICK-CLAC / Vidage quick-clac

LEO

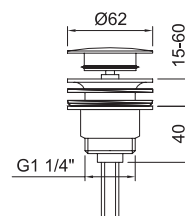

Pop-up quick-clac 1 1/4\"

Válvula desagüe universal sistema quick-clac 1 1/4\"

Vidage universel quick-clac 1 1/4\"

REF.	RRP INC VAT	UOM
61819UK	32.39	PCS



Metálico
Metallic · Métallique

BRONZE



BASIN CLICK WASTE
 VÁLVULA DESAGÜE SISTEMA QUICK-CLAC / Vidage quick-clac

LEO

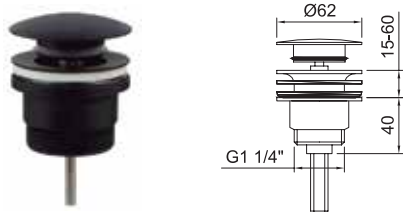

Pop-up quick-clac 1 1/4".
 Válvula desagüe universal sistema quick-clac 1 1/4".
 Vidage universel quick-clac 1 1/4".

REF.	RRP INC VAT	UOM
62123UK  	22.79	PCS



Sintético
 Synthetic - Synthétique

BLACK





82 KITCHEN

- 82 ALPINA CLASSIC
- 83 ALPINA RIGHT
- 86 ALPINA ROUND
- 88 4IN1 INSTANT HOT WATER TAP
- 90 CHEF SLIM
- 90 CHEF 6
- 91 CHEF 5
- 91 CHEF 1
- 91 ALPINA METAL
- 92 WATER FILTRATION
- 96 ANTIGONA
- 98 RUNE
- 100 ELEKTRO
- 101 ARBON
- 102 TORMES
- 104 GO!
- 105 ROCKET
- 106 PICA
- 108 ARAYA MERCIA URBAN
- 110 ARAYA MERCIA QT
- 111 ARAYA MERCIA MODERN
- 112 PERFORMA

Alpina Classic



61902UK
ALPINA CLASSIC

SINK MIXER
Fregadero
Mélangeur évier

ALPINA CLASSIC

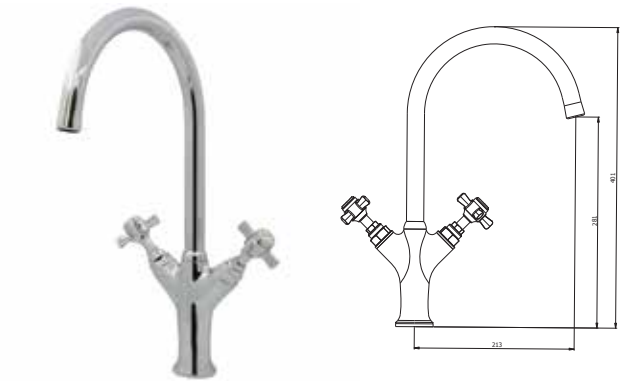

Two-handled sink mixer with aerator, swivel tube spout and flexible hoses 1/2" >350mm.
Fregadero bimando con aireador, caño giratorio y flexibles 1/2" >350mm.
Mélangeur évier avec aérateur, bec orientable et flexibles de raccordement 1/2" >350mm.

REF.	RRP INC VAT	UOM
4k5009UK  	191.99	PCS



SINK MIXER
Fregadero
Mélangeur évier

ALPINA CLASSIC

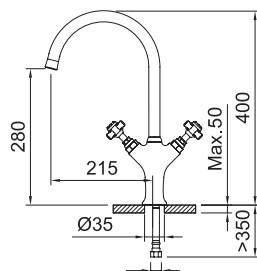

Two-handled sink mixer with aerator, swivel tube spout and flexible hoses 1/2" >350mm.
Fregadero bimando con aireador, caño giratorio y flexibles 1/2" >350mm.
Mélangeur évier avec aérateur, bec orientable et flexibles de raccordement 1/2" >350mm.

REF.	RRP INC VAT	UOM
61902UK  	251.99	PCS

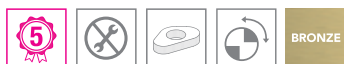

SINK MIXER
Fregadero
Mélangeur évier

ALPINA CLASSIC

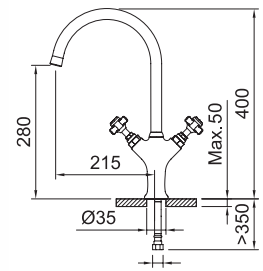

Two-handled sink mixer with aerator, swivel tube spout and flexible hoses 1/2" >350mm.
Fregadero bimando con aireador, caño giratorio y flexibles 1/2" >350mm.
Mélangeur évier avec aérateur, bec orientable et flexibles de raccordement 1/2" >350mm.

REF.	RRP INC VAT	UOM
61903UK  	221.99	PCS





SINK MIXER
Fregadero
Mitigeur évier

ALPINA RIGHT

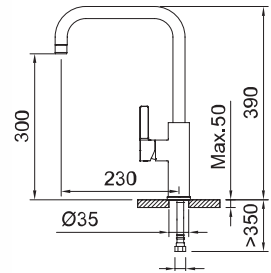

Single-lever sink mixer with aerator, swivel spout and flexible hoses 1/2" >350mm.
Fregadero monomando con aireador, caño giratorio y flexibles 1/2" >350mm.
Mitigeur évier avec aérateur, bec orientable et flexibles de raccordement 1/2" >350mm.

REF.	Unified Water Label	RRP INC VAT	UOM
61185UK	5 l/min	161.99	PCS



SINK MIXER
Fregadero
Mitigeur évier

ALPINA RIGHT

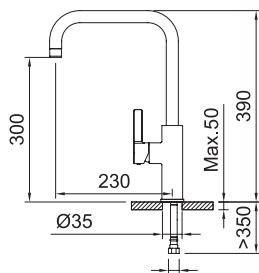

Single-lever sink mixer with aerator, swivel spout and flexible hoses 1/2" >350mm.
Fregadero monomando con aireador, caño giratorio y flexibles 1/2" >350mm.
Mitigeur évier avec aérateur, bec orientable et flexibles de raccordement 1/2" >350mm.

REF.	Unified Water Label	RRP INC VAT	UOM
61188UK	5 l/min	185.99	PCS



SINK MIXER
Fregadero
Mitigeur évier

ALPINA RIGHT

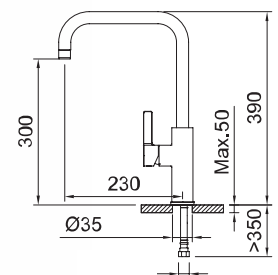

Single-lever sink mixer with aerator, swivel spout and flexible hoses 1/2" >350mm.
Fregadero monomando con aireador, caño giratorio y flexibles 1/2" >350mm.
Mitigeur évier avec aérateur, bec orientable et flexibles de raccordement 1/2" >350mm.

REF.	Unified Water Label	RRP INC VAT	UOM
61186UK	5 l/min	173.99	PCS



Alpina Right



SINK MIXER
Fregadero
Mélangeur évier

ALPINA RIGHT

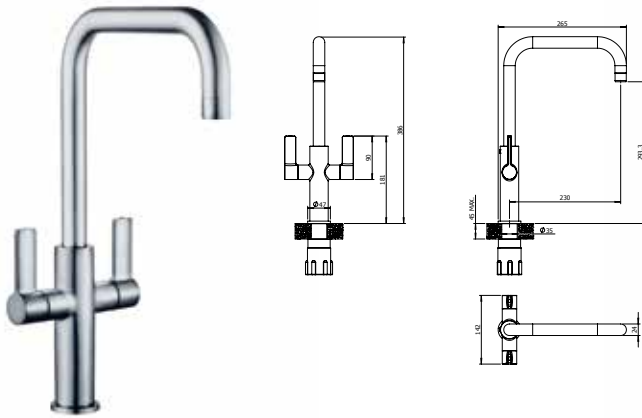

Two-handled sink mixer with aerator, swivel tube spout and flexible hoses 1/2" >350mm.
Fregadero bimando con aireador, caño giratorio y flexibles 1/2" >350mm.
Mélangeur évier avec aérateur, bec orientable et flexibles de raccordement 1/2" >350mm.

REF.	RRP INC VAT	UOM
922100UK	209.99	PCS



SINK MIXER
Fregadero
Mélangeur évier

ALPINA RIGHT

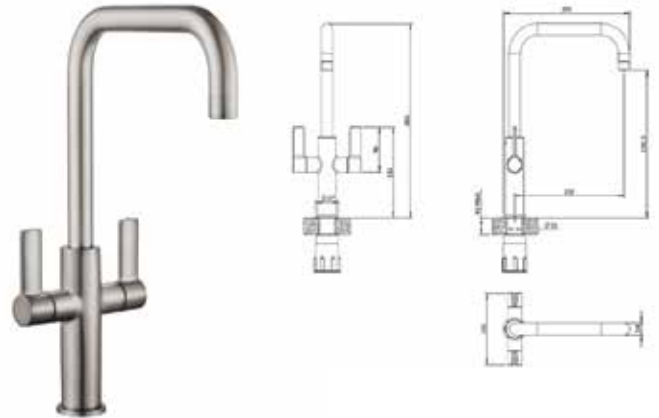

Two-handled sink mixer with aerator, swivel tube spout and flexible hoses 1/2" >350mm.
Fregadero bimando con aireador, caño giratorio y flexibles 1/2" >350mm.
Mélangeur évier avec aérateur, bec orientable et flexibles de raccordement 1/2" >350mm.

REF.	RRP INC VAT	UOM
922101UK	233.99	PCS



SINK MIXER
Fregadero
Mélangeur évier

ALPINA RIGHT



Two-handled sink mixer with aerator, swivel tube spout and flexible hoses 1/2" >350mm.
Fregadero bimando con aireador, caño giratorio y flexibles 1/2" >350mm.
Mélangeur évier avec aérateur, bec orientable et flexibles de raccordement 1/2" >350mm.

REF.	RRP INC VAT	UOM
922102UK	245.99	PCS



Alpina Round

SINK MIXER

Fregadero
Mitigeur évier

ALPINA ROUND

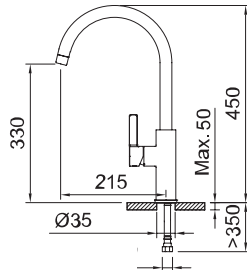

Single-lever sink mixer with aerator, swivel spout and flexible hoses 1/2" >350mm.
Fregadero monomando con aireador, caño giratorio y flexibles 1/2" >350mm.
Mitigeur évier avec aérateur, bec orientable et flexibles de raccordement 1/2" >350mm.

REF.	Unified Water Label	RRP INC VAT	UOM
61189UK	5 l/min	161.99	PCS



SINK MIXER

Fregadero
Mitigeur évier

ALPINA ROUND

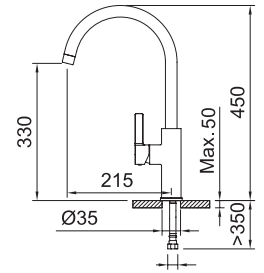

Single-lever sink mixer with aerator, swivel spout and flexible hoses 1/2" >350mm.
Fregadero monomando con aireador, caño giratorio y flexibles 1/2" >350mm.
Mitigeur évier avec aérateur, bec orientable et flexibles de raccordement 1/2" >350mm.

REF.	Unified Water Label	RRP INC VAT	UOM
61190UK	5 l/min	173.99	PCS



SINK MIXER

Fregadero
Mitigeur évier

ALPINA ROUND

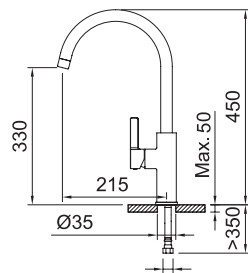

Single-lever sink mixer with aerator, swivel spout and flexible hoses 1/2" >350mm.
Fregadero monomando con aireador, caño giratorio y flexibles 1/2" >350mm.
Mitigeur évier avec aérateur, bec orientable et flexibles de raccordement 1/2" >350mm.

REF.	Unified Water Label	RRP INC VAT	UOM
61192UK	5 l/min	185.99	PCS



SISTEMA COLD OPEN
Ahorro de energía
Apertura en frío.

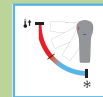

Cold Open system. Save energy.
It opens in cold position.

Système Cold Open. Économie de énergie.
Système d'ouverture en eau froide.





61192UK
ALPINA ROUND

4in1 Instant Hot Water Taps



INSTANT HOT WATER TAPS

Fregadero
Mélangeur évier

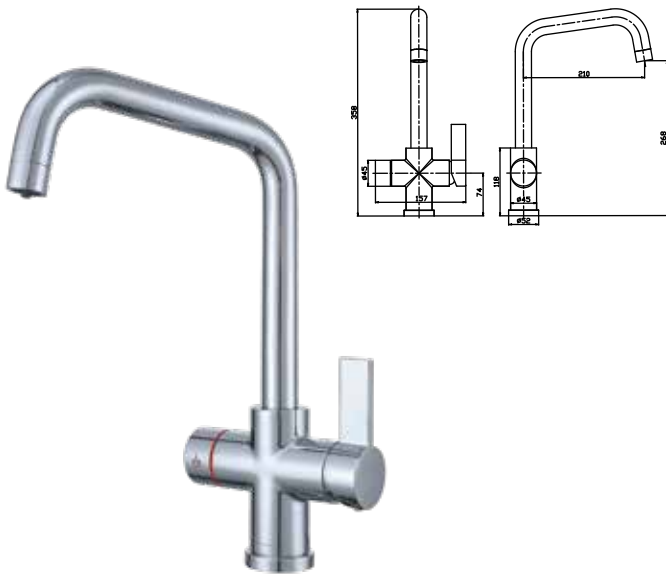

REF.	RRP INC VAT	UOM
922221UK	959.99	PCS

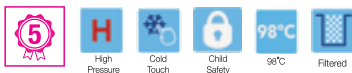

INSTANT HOT WATER TAPS

Fregadero
Mélangeur évier

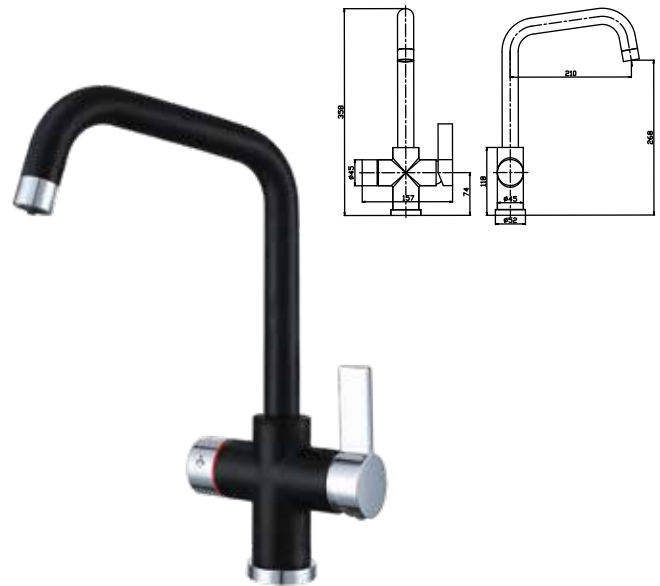

REF.	RRP INC VAT	UOM
922222UK	1049.99	PCS

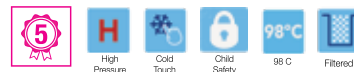

INSTANT HOT WATER TAPS

Fregadero
Mélangeur évier

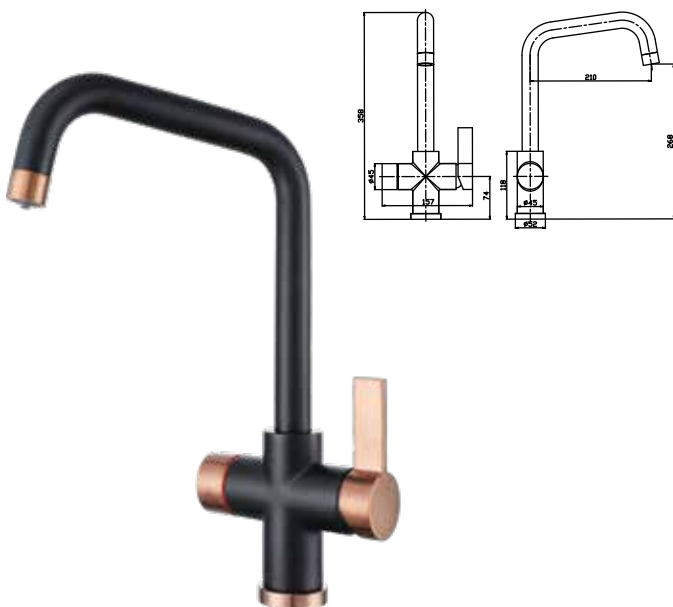

REF.	RRP INC VAT	UOM
922223UK	1049.99	PCS

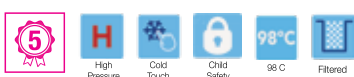

Instant Hot Water

Enjoy instant hot water, ideal for making tea, coffee, or accelerating your cooking process.



Filtered Cold Water

Experience clean, filtered cold water for drinking or cooking, straight from your tap.



Normal Hot Water

Standard hot water for everyday kitchen tasks, including washing dishes and food preparation.



Normal Cold Water

Regular cold water for all your kitchen needs, ensuring full tap functionality.

SINK MIXER
Fregadero
Mitigeur évier



**CHEF SLIM
BLACK**

Ø25 CARTUCHO
CARTRIDGE
CARTOUCHE

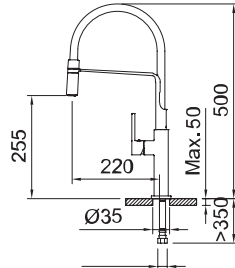

Single-lever sink mixer with aerator, swivel spout and flexible hoses 1/2" >350mm.
Fregadero monomando con aireador, caño giratorio y flexibles 1/2" >350mm.
Mitigeur évier avec aérateur, bec orientable et flexibles de raccordement 1/2" >350mm.

REF.	RRP INC VAT	UOM
60146UK  7 l/min	209.99	PCS



SINK MIXER
Fregadero
Mitigeur évier



**CHEF SLIM
BRUSHED NICKEL**

Ø25 CARTUCHO
CARTRIDGE
CARTOUCHE

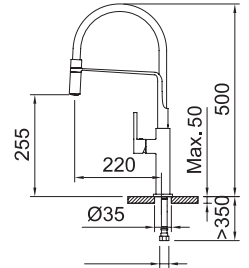

Single-lever sink mixer with aerator, swivel spout and flexible hoses 1/2" >350mm.
Fregadero monomando con aireador, caño giratorio y flexibles 1/2" >350mm.
Mitigeur évier avec aérateur, bec orientable et flexibles de raccordement 1/2" >350mm.

REF.	RRP INC VAT	UOM
60144UK  7 l/min	227.99	PCS



SINK MIXER
Fregadero
Mitigeur évier



**CHEF SLIM
CHROME**

Ø25 CARTUCHO
CARTRIDGE
CARTOUCHE

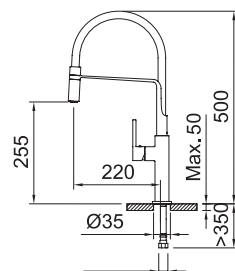

Single-lever sink mixer with aerator, swivel spout and flexible hoses 1/2" >350mm.
Fregadero monomando con aireador, caño giratorio y flexibles 1/2" >350mm.
Mitigeur évier avec aérateur, bec orientable et flexibles de raccordement 1/2" >350mm.

REF.	RRP INC VAT	UOM
60143UK  7 l/min	197.99	PCS



SINK MIXER
Fregadero
Mitigeur évier



CHEF 6

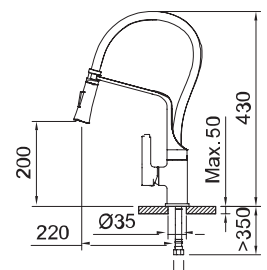

Single-lever sink mixer with aerator, swivel spout and flexible hoses 1/2" >350mm.
Fregadero monomando con aireador, caño giratorio y flexibles 1/2" >350mm.
Mitigeur évier avec aérateur, bec orientable et flexibles de raccordement 1/2" >350mm.

REF.	RRP INC VAT	UOM
99735UK	257.99	PCS



SINK MIXER
Fregadero
Mitigeur évier

CHEF 5

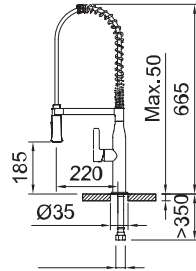

Single-lever sink mixer with aerator, swivel spout and flexible hoses 1/2" >350mm.
Fregadero monomando con aireador, caño giratorio y flexibles 1/2" >350mm.
Mitigeur évier avec aérateur, bec orientable et flexibles de raccordement 1/2" >350mm.

REF.	RRP INC VAT	UOM
99444UK	341.99	PCS



SINK MIXER
Fregadero
Mitigeur évier

CHEF 1

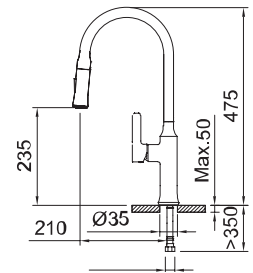

Single-lever sink mixer with aerator, swivel spout and flexible hoses 1/2" >350mm.
Fregadero monomando con aireador, caño giratorio y flexibles 1/2" >350mm.
Mitigeur évier avec aérateur, bec orientable et flexibles de raccordement 1/2" >350mm.

REF.	RRP INC VAT	UOM
99440UK	215.99	PCS

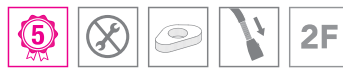

SINK MIXER
Fregadero
Mitigeur évier

ALPINA METAL
CHROME

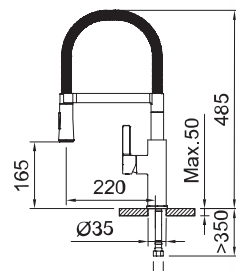

Single-lever sink mixer with aerator, swivel spout and flexible hoses 1/2" >350mm.
Fregadero monomando con aireador, caño giratorio y flexibles 1/2" >350mm.
Mitigeur évier avec aérateur, bec orientable et flexibles de raccordement 1/2" >350mm.

REF.	RRP INC VAT	UOM
61180UK	377.99	PCS



SINK MIXER
Fregadero
Mitigeur évier

ALPINA METAL
BRUSHED NICKEL

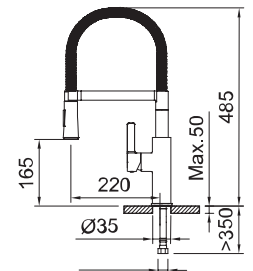

Single-lever sink mixer with aerator, swivel spout and flexible hoses 1/2" >350mm.
Fregadero monomando con aireador, caño giratorio y flexibles 1/2" >350mm.
Mitigeur évier avec aérateur, bec orientable et flexibles de raccordement 1/2" >350mm.

REF.	RRP INC VAT	UOM
922152UK	395.99	PCS



Ultrafiltration water treatment unit

  *Video / Vidéo de uso / Vidéo tutorielle*





So compact, it can be installed in the furniture under the sink!

Tan compacto que se puede instalar y guardar en el mueble de debajo del fregadero!

Si compact qu'il peut d'installer et se ranger dans le meuble sous l'évier!

No electricity.

Autonomous unit without depending on an electrical network.

SIN CONSUMO ELÉCTRICO

El equipo funciona de una manera autónoma sin depender de un sistema eléctrico externo.

Pas de consommation d'électricité.

L'équipement fonctionne de manière autonome sans dépendre d'un système électrique externe.

No more plastics.

Non carry more bottles and non plastic produce.

NO MÁS PLÁSTICOS

No transportarás botellas ni generarás plásticos innecesarios.

Plus de plastique.

Permet de réduire l'utilisation de bouteilles d'eau et la consommation de plastique

Healthy water.

Keep minerals in water, providing high quality filtered water.

AGUA SALUDABLE

Mantiene los minerales en el agua, proporcionando agua filtrada de buena calidad.

Eau saine.

Il maintient les minéraux dans l'eau, fournissant une eau filtrée de bonne qualité.

Non water rejection.

Environmental friendly, filtering 100% of the water.

SIN RECHAZO DE AGUA

El 100% del agua es filtrada, promoviendo y respetando el medio ambiente.

Pas de perte d'eau.

100% de l'eau est filtrée, favorisant le respect de l'environnement.

Filter progress bar
Barra de progreso de los filtros
Indicateur de progression du filtre

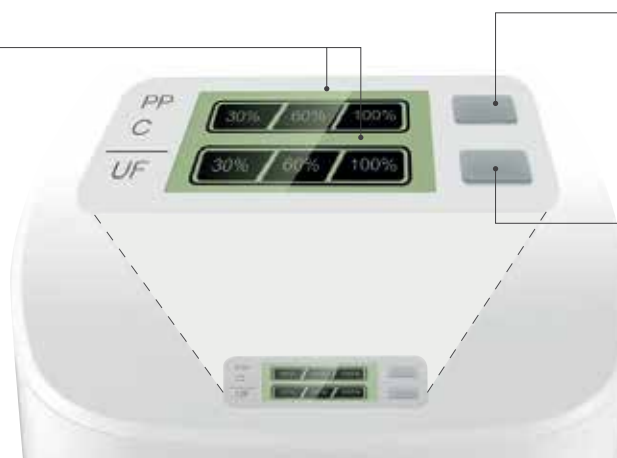

Reset button for PP, C1 and C2 filters

Botón reset de los filtros PP, C1 y C2

Bouton de réinitialisation pour les filtres PP, C1 et C2

Reset button for UF filter

Botón reset del filtro UF

Bouton de réinitialisation pour le filtre UF

Ultrafiltration water treatment unit



Caudal

Flow rate / Débit

1,2 - 2,5 L/min

Presión de trabajo

Working pressure / Pression de travail

1 - 4 bar

Agua filtrada
Filtered water
Eau filtrée

Agua de red
Mixed water
Eau du réseau

Cartucho PP: Polipropileno

Cartridge PP: Polypropylene
Cartouche PP: Polypropylène

Filtra partículas, sedimentos, óxido y arena.

Reduce the particulates, sediment, rust and sand.

Filtre les particules, les sédiments, la rouille et le sable.

5-10 µm

Cartucho C1: Pre-Carbón

Cartridge C1: Pre Carbon
Cartouche C1: Pré-Carbone

Reduce el cloro y absorbe las partículas pequeñas.

Reduce the chlorine and absorb smaller particulates.

Réduit le chlore et absorbe les petites particules.

1 µm

3 way sink mixer for water quality equipment

FREGADERO 3 VIAS PARA EQUIPOS DE TRATAMIENTO DEL AGUA

Mitigeur 3 voies pour équipement de traitement de l'eau

RECOMMENDED FOR LOW PRESSURE EQUIPMENT (FREE OUTLET)

RECOMENDADO PARA EQUIPOS CON POCA PRESIÓN (SALIDA LIBRE)

RECOMMANDÉ POUR LES ÉQUIPEMENTS À BASSE PRESSION (SORTIE LIBRE)

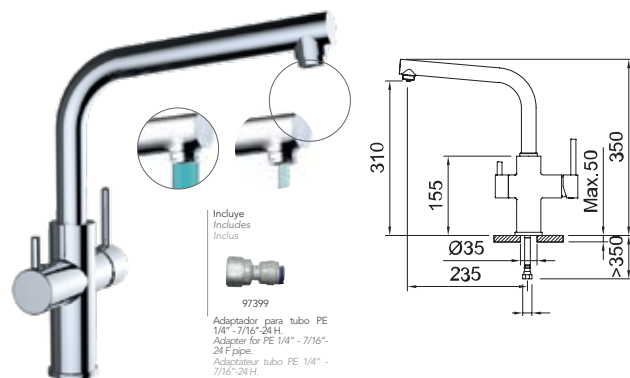

3-way sink for water treatment equipment with 2 water outlets, swivel spout and flexible hoses 1/2" >350mm.

Fregadero 3 vías para equipos de tratamiento del agua, con 2 salidas de agua, caño giratorio y flexibles 1/2" >350mm.

Mitigeur évier 3 voies pour équipement de traitement d'eau avec 2 sorties d'eau, bec orientable et flexibles de raccordement 1/2" >350mm.

Cartucho C2: Post-Carbón

Cartridge C2: Post Carbon
Cartouche C2: Post-Carbone

Elimina el olor y el mal sabor.

Reduce the odor and bad taste.

Élimine les odeurs et le mauvais goût de l'eau.

1 µm

Cartucho UF: Ultrafiltración

Cartridge UF: Ultrafiltration
Cartouche UF: Ultrafiltration

Filtra organismos y bacterias.

Reduce organism and bacteria.

Filtre les organismes et les bactéries.

0,02-0,1 µm

REF.	RRP INC VAT	UOM
61102UK 	251.99	PCS



METAL FREE

PURE

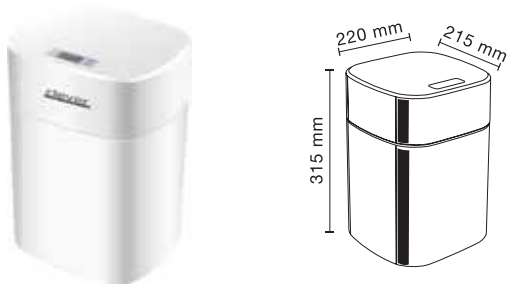

Ultrafiltration water treatment unit.
Equipo de ultrafiltración para el tratamiento del agua.
Unité de traitement d'eau par ultrafiltration.

REF.	RRP INC VAT	UOM
61428UK 	249.99	PCS



3 WAY SINK MIXER FOR WATER QUALITY EQUIPMENT
FREGADERO 3 VIAS PARA EQUIPOS DE TRATAMIENTO DEL AGUA
Mitigeur 3 voies pour équipement de traitement de l'eau

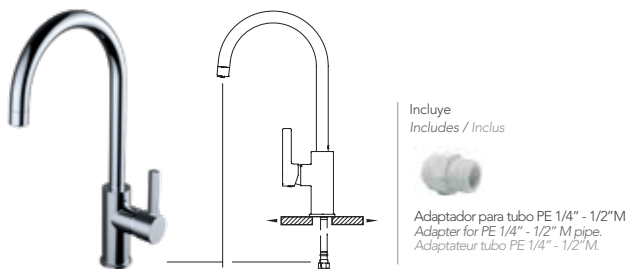

3-way single-lever sink mixer for water treatment equipment with 2 water outlets, swivel spout and flexible hoses 1/2" >350mm.

Fregadero monomando 3 vías para equipos de tratamiento del agua, con 2 salidas de agua, caño giratorio y flexibles 1/2" >350mm.

Mitigeur évier 3 voies pour équipement de traitement d'eau avec 2 sorties d'eau, bec orientable et flexibles de raccordement 1/2" >350mm.

REF.	RRP INC VAT	UOM
61101UK	215.99	PCS



MIXED WATER AND FILTERED WATER ON THE SAME HANDLE
AGUA MEZCLADA Y AGUA FILTRADA DESDE UNA SOLA MANETA
EAU DU RÉSEAU ET EAU PURIFIÉE DEPUIS UNE SEULE MANETTE



3 WAY SINK MIXER FOR WATER QUALITY EQUIPMENT

FREGADERO 3 VIAS PARA EQUIPOS DE TRATAMIENTO DEL AGUA

Mitigeur 3 voies pour équipement de traitement de l'eau

ROUND

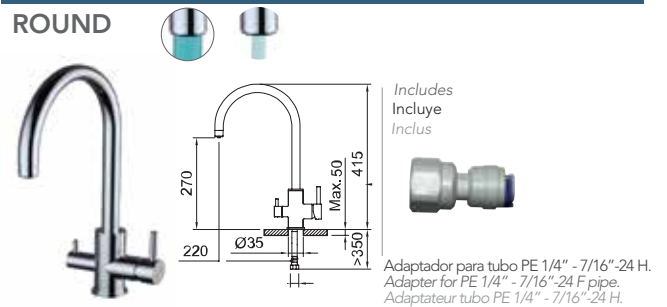

3-way sink for water treatment equipment with 2 water outlets, swivel spout and flexible hoses 1/2" >350mm.

Fregadero 3 vías para equipos de tratamiento del agua, con 2 salidas de agua, caño giratorio y flexibles 1/2" >350mm.

Mitigeur évier 3 voies pour équipement de traitement d'eau avec 2 sorties d'eau, bec orientable et flexibles de raccordement 1/2" >350mm.

REF.	RRP INC VAT	UOM
60150UK	275.99	PCS

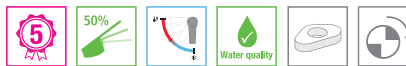

3 WAY SINK MIXER FOR WATER QUALITY EQUIPMENT

FREGADERO 3 VIAS PARA EQUIPOS DE TRATAMIENTO DEL AGUA

Mitigeur 3 voies pour équipement de traitement de l'eau

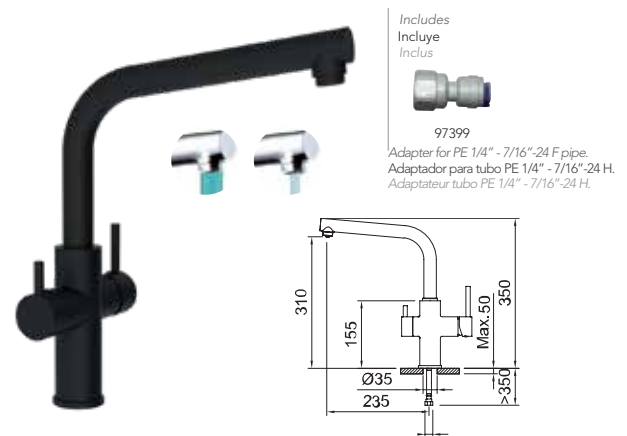

3-way sink for water treatment equipment with 2 water outlets, swivel spout and flexible hoses 1/2" >350mm.

Fregadero 3 vías para equipos de tratamiento del agua, con 2 salidas de agua, caño giratorio y flexibles 1/2" >350mm.

Mitigeur évier 3 voies pour équipement de traitement d'eau avec 2 sorties d'eau, bec orientable et flexibles de raccordement 1/2" >350mm.

REF.	RRP INC VAT	UOM
61237UK 	275.99	PCS



SINK MIXER

Fregadero
Mélangeur évier

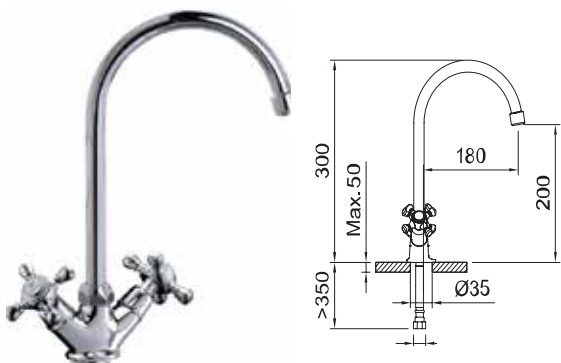

Two-handed sink mixer with aerator, swivel tube swan spout and flexible hoses 1/2" >350mm.

Fregadero bimando con aireador, caño conformado giratorio y flexibles 1/2" >350mm.

Mélangeur évier avec aérateur, bec orientable et flexibles de raccordement 1/2" >350mm.

REF.	RRP INC VAT	UOM
92049UK	107.99	PCS



SINK MIXER

Fregadero
Mélangeur évier

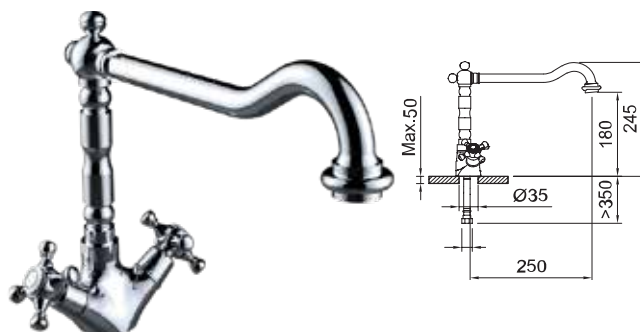

Two-handed sink mixer with aerator, swivel tube horizontal spout and flexible hoses 1/2" >350mm.

Fregadero bimando con aireador, caño conformado giratorio y flexibles 1/2" >350mm.

Mélangeur évier avec aérateur, bec orientable et flexibles de raccordement 1/2" >350mm.

REF.	RRP INC VAT	UOM
61772UK	227.99	PCS



SINK MIXER

Fregadero
Mélangeur évier

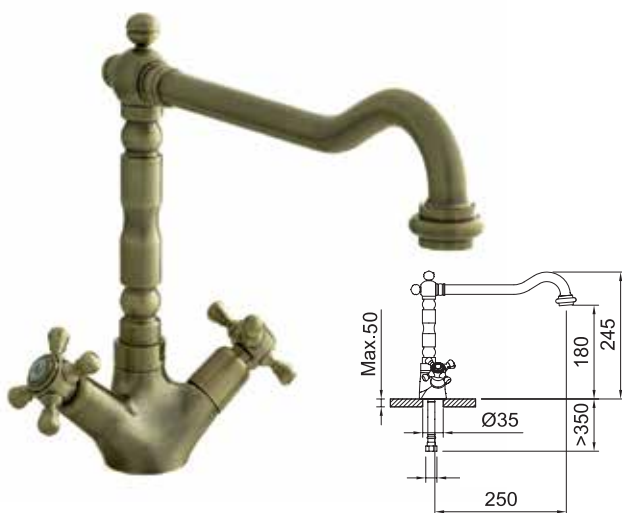

Two-handed sink mixer with aerator, swivel tube horizontal spout and flexible hoses 1/2" >350mm.

Fregadero bimando con aireador, caño conformado giratorio y flexibles 1/2" >350mm.

Mélangeur évier avec aérateur, bec orientable et flexibles de raccordement 1/2" >350mm.

REF.	RRP INC VAT	UOM
61773UK	251.99	PCS



SINK MIXER

Fregadero
Mélangeur évier

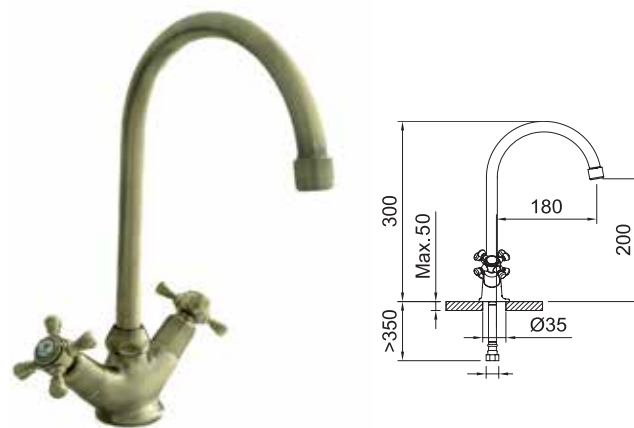

Two-handed sink mixer with aerator, swivel tube swan spout and flexible hoses 1/2" >350mm.

Fregadero bimando con aireador, caño conformado giratorio y flexibles 1/2" >350mm.

Mélangeur évier avec aérateur, bec orientable et flexibles de raccordement 1/2" >350mm.

REF.	RRP INC VAT	UOM
61771UK	125.99	PCS





61772UK
antigona



SINK MIXER
Fregadero
Mélangeur évier

RUNE

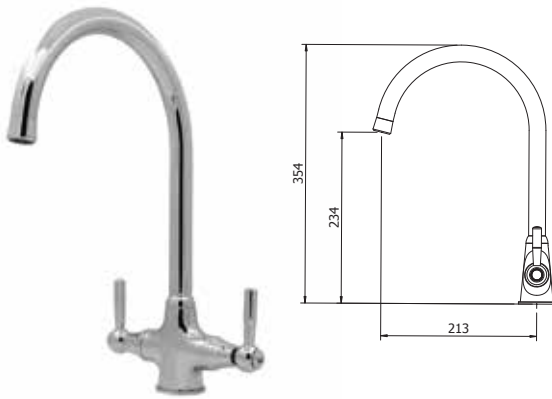

Two-handed sink mixer with aerator, swivel tube spout and flexible hoses 1/2" >350mm.
Fregadero bimando con aireador, caño giratorio y flexibles 1/2" >350mm.
Mélangeur évier avec aérateur, bec orientable et flexibles de raccordement 1/2" >350mm.

REF.	RRP INC VAT	UOM
4P1061UK  3.9l/min	179.99	PCS



SINK MIXER
Fregadero
Mélangeur évier

RUNE

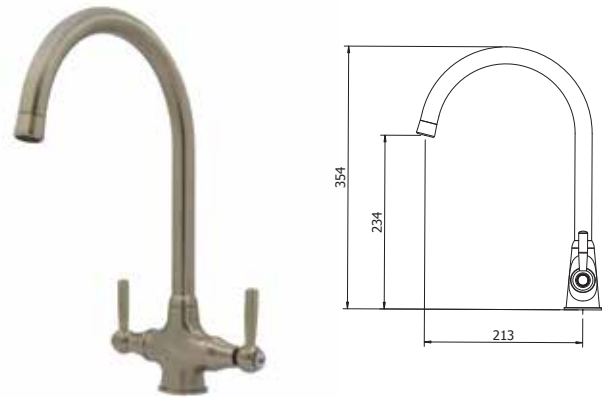

Two-handed sink mixer with aerator, swivel tube spout and flexible hoses 1/2" >350mm.
Fregadero bimando con aireador, caño giratorio y flexibles 1/2" >350mm.
Mélangeur évier avec aérateur, bec orientable et flexibles de raccordement 1/2" >350mm.

REF.	RRP INC VAT	UOM
4P1070UK  3.9l/min	191.99	PCS



SINK MIXER
Fregadero
Mélangeur évier

RUNE

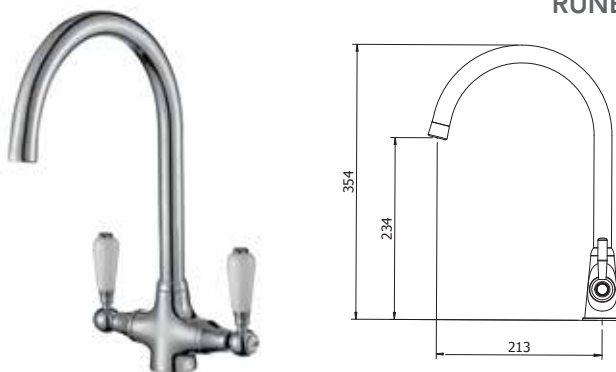

Two-handed sink mixer with aerator, swivel tube spout and flexible hoses 1/2" >350mm.
Fregadero bimando con aireador, caño giratorio y flexibles 1/2" >350mm.
Mélangeur évier avec aérateur, bec orientable et flexibles de raccordement 1/2" >350mm.

REF.	RRP INC VAT	UOM
922022UK  3.9 l/min	203.99	PCS



SINK MIXER
Fregadero
Mélangeur évier

RUNE

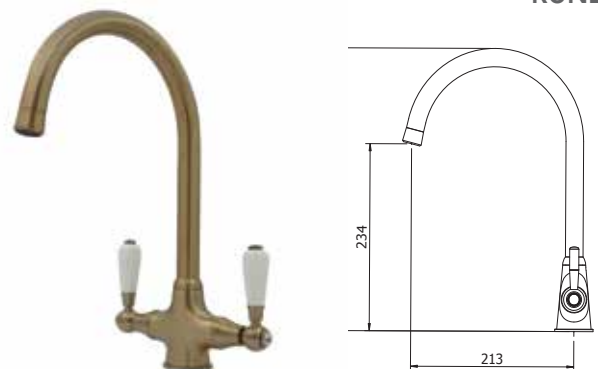

Two-handed sink mixer with aerator, swivel tube spout and flexible hoses 1/2" >350mm.
Fregadero bimando con aireador, caño giratorio y flexibles 1/2" >350mm.
Mélangeur évier avec aérateur, bec orientable et flexibles de raccordement 1/2" >350mm.

REF.	RRP INC VAT	UOM
4P1065UK  3.9l/min	215.99	PCS





SINK MIXER

Fregadero
Mélangeur évier

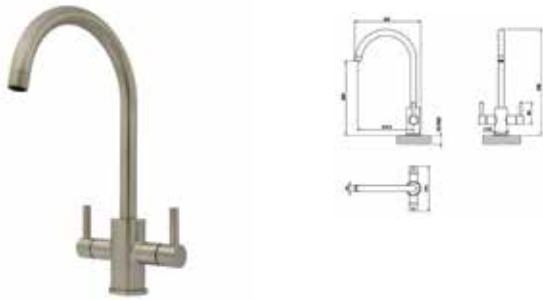

Two-handed sink mixer with aerator, swivel tube spout and flexible hoses 1/2" >350mm.
Fregadero bimando con aireador, caño giratorio y flexibles 1/2" >350mm.
Mélangeur évier avec aérateur, bec orientable et flexibles de raccordement 1/2" >350mm.

REF.	RRP INC VAT	UOM
487004UK	131.99	PCS

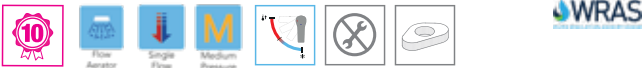

SINK MIXER

Fregadero
Mélangeur évier

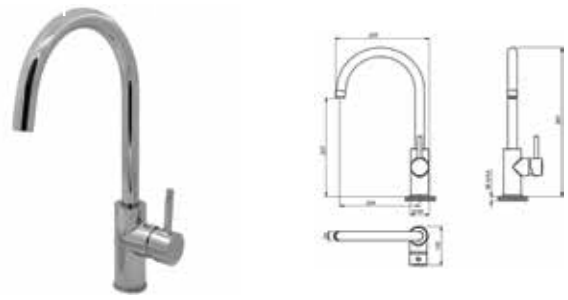

REF.	RRP INC VAT	UOM
487004UK	131.99	PCS



SINK MIXER

Fregadero
Mélangeur évier

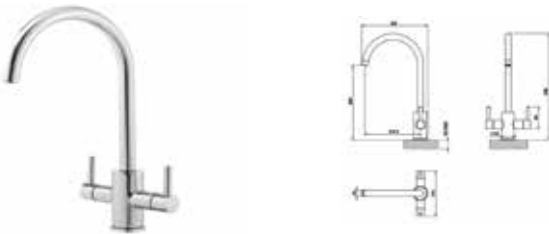

Two-handed sink mixer with aerator, swivel tube spout and flexible hoses 1/2" >350mm.
Fregadero bimando con aireador, caño giratorio y flexibles 1/2" >350mm.
Mélangeur évier avec aérateur, bec orientable et flexibles de raccordement 1/2" >350mm.

REF.	RRP INC VAT	UOM
487000UK	179.99	PCS



Arbon

SINK MIXER

Fregadero
Mélangeur évier

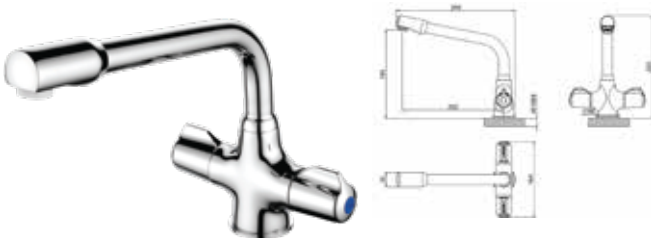

REF.	RRP INC VAT	UOM
452101UK	143.99	PCS





SINK MIXER
 Fregadero
 Mélangeur évier

TORMES



REF.	RRP INC VAT	UOM
4S1102UK	131.99	PCS



HORIZONTAL SINK MIXER

Fregadero horizontal
Mitigeur évier bec bas

GO!

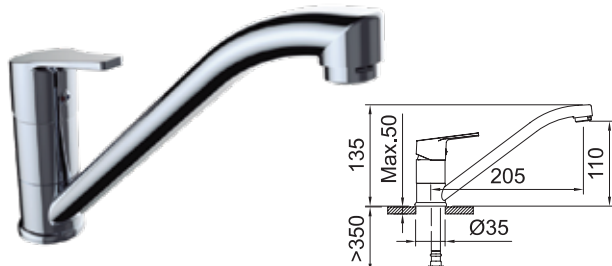

Single-lever sink mixer with aerator, swivel spout and flexible hoses 1/2" >350mm.
Fregadero monomando con aireador, caño giratorio y flexibles 1/2" >350mm.
Mitigeur évier avec aérateur, bec orientable et flexibles de raccordement 1/2" >350mm.

REF.	RRP INC VAT	UOM
61545UK	65.99	PCS



SINK MIXER

Fregadero
Mitigeur évier

GO!2



Single-lever sink mixer with aerator, swivel tube spout and flexible hoses 1/2" >350mm.
Fregadero monomando con aireador, caño conformado giratorio y flexibles 1/2" >350mm.
Mitigeur évier avec aérateur, bec orientable et flexibles de raccordement 1/2" >350mm.

REF.	RRP INC VAT	UOM
62135UK	83.99	PCS



SINK MIXER

Fregadero
Mitigeur évier

GO!

COMING SOON

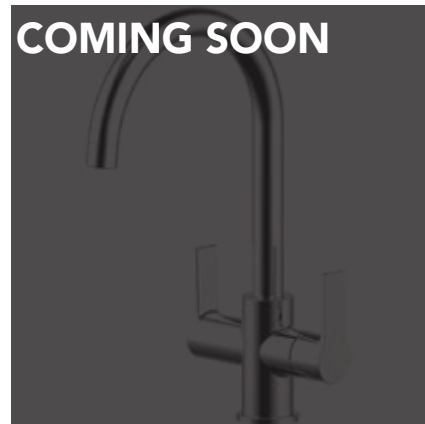

Twin handle sink mixer with aerator, swivel spout and flexible hoses 1/2" >350mm.
Fregadero monomando con aireador, caño giratorio y flexibles 1/2" >350mm.
Mitigeur évier avec aérateur, bec orientable et flexibles de raccordement 1/2" >350mm.

REF.	RRP INC VAT	UOM
TBC	TBC	PCS

SINK MIXER

Fregadero
Mitigeur évier

GO!2

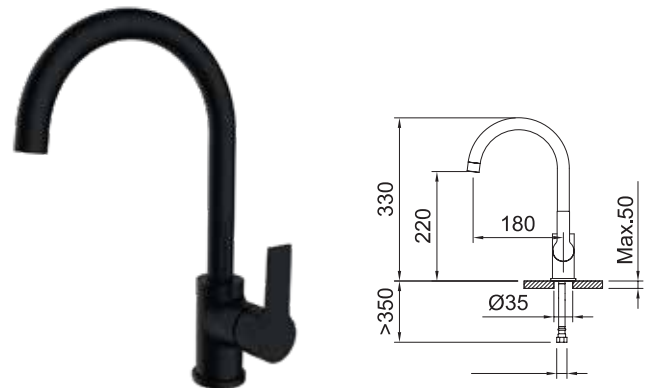

Single-lever sink mixer with aerator, swivel tube spout and flexible hoses 1/2" >350mm.
Fregadero monomando con aireador, caño conformado giratorio y flexibles 1/2" >350mm.
Mitigeur évier avec aérateur, bec orientable et flexibles de raccordement 1/2" >350mm.

REF.	RRP INC VAT	UOM
62145UK	89.99	PCS





SINK MIXER
Fregadero
Mitigeur évier

ROCKET

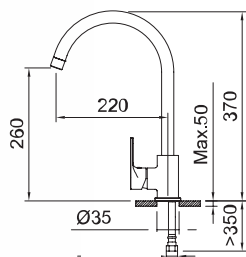

Single-lever sink mixer with aerator, swivel spout and flexible hoses 1/2" >350mm.
Fregadero monomando con aireador, caño giratorio y flexibles 1/2" >350mm.
Mitigeur évier avec aérateur, bec orientable et flexibles de raccordement 1/2" >350mm.

REF.		RRP INC VAT	UOM
62069UK		107.99	PCS



SINK MIXER
Fregadero
Mitigeur évier

ROCKET

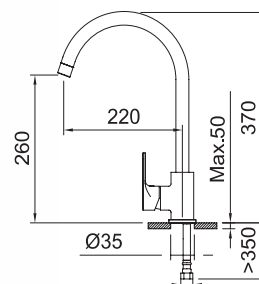

Single-lever sink mixer with aerator, swivel spout and flexible hoses 1/2" >350mm.
Fregadero monomando con aireador, caño giratorio y flexibles 1/2" >350mm.
Mitigeur évier avec aérateur, bec orientable et flexibles de raccordement 1/2" >350mm.

REF.		RRP INC VAT	UOM
62084UK		113.99	PCS





SINK MIXER
Fregadero
Mélangeur évier

PICA



SINK MIXER
Fregadero
Mélangeur évier

PICA



REF.	United Water Label	RRP INC VAT	UOM
922319UK	5 l/min	119.99	PCS



REF.	United Water Label	RRP INC VAT	UOM
922318UK	5 l/min	95.99	PCS

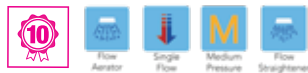

Araya Mercia Urban



SINK MIXER

Fregadero
Mélangeur évier



Single-lever sink mixer with aerator, swivel spout and flexible hoses 1/2" >350mm.
Fregadero monomando con aireador, caño giratorio y flexibles 1/2" >350mm.
Mitigeur évier avec aérateur, bec orientable et flexibles de raccordement 1/2" >350mm.

REF.	RRP INC VAT	UOM
4S1209UK	113.99	PCS



HIGH NECK SINK TAPS PAIR

Fregadero
Mélangeur évier

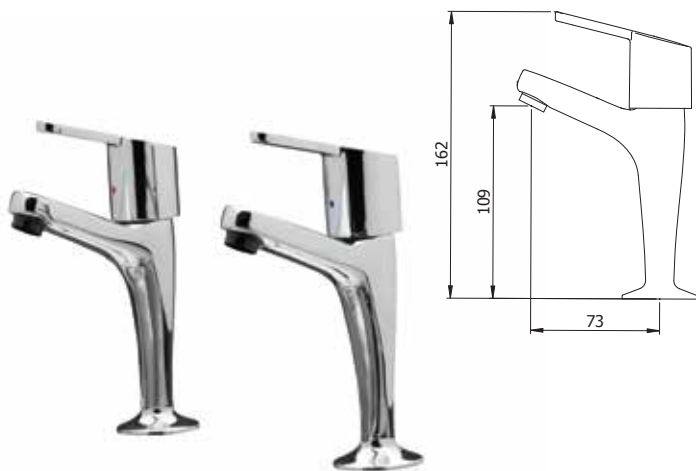

REF.	RRP INC VAT	UOM
4S1211UK	83.99	PCS



DECK MOUNTED SINK MIXER

Fregadero
Mélangeur évier

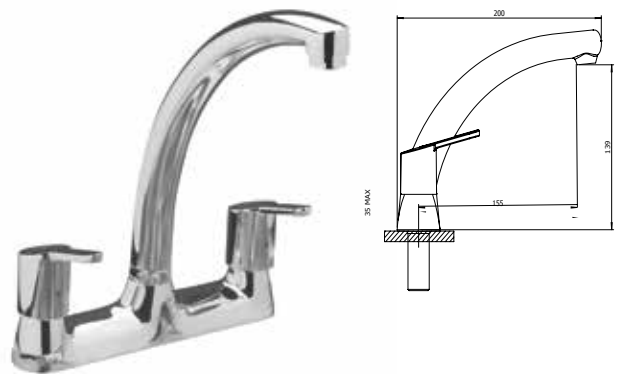

Two-handed sink mixer with aerator, swivel tube spout and flexible hoses 1/2" >350mm.
Fregadero bimando con aireador, caño conformado giratorio y flexibles 1/2" >350mm.
Mélangeur évier avec aérateur, bec orientable et flexibles de raccordement 1/2" >350mm.

REF.	RRP INC VAT	UOM
4S1210UK	149.99	PCS



LONG NECK SINK MIXER

Fregadero
Mélangeur évier

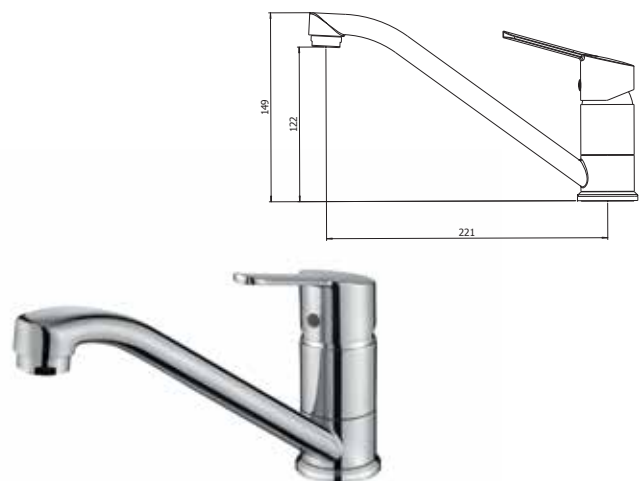

Single-lever sink mixer with aerator, swivel spout and flexible hoses 1/2" >350mm.
Fregadero monomando con aireador, caño giratorio y flexibles 1/2" >350mm.
Mitigeur évier avec aérateur, bec orientable et flexibles de raccordement 1/2" >350mm.

REF.	RRP INC VAT	UOM
922020UK	77.99	PCS



Araya Mercia QT

SINK MIXER Fregadero Mélangeur évier



REF.	RRP INC VAT	UOM
922069UK	101.99	PCS



DECK MOUNTED SINK MIXER Fregadero Mélangeur évier

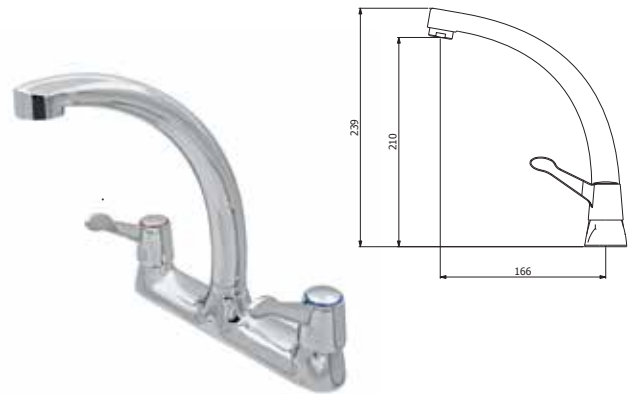

REF.	RRP INC VAT	UOM
922075UK	119.99	PCS



HIGH NECK SINK TAPS PAIR Fregadero Mélangeur évier

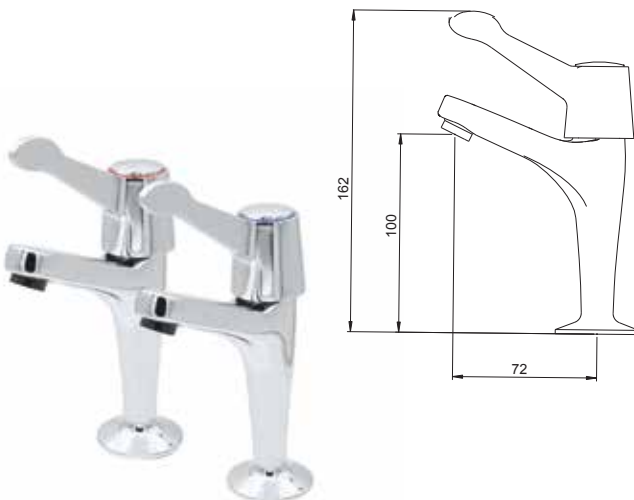

REF.	RRP INC VAT	UOM
922068UK	77.99	PCS



HIGH NECK SINK TAPS PAIR

Fregadero
Mélangeur évier

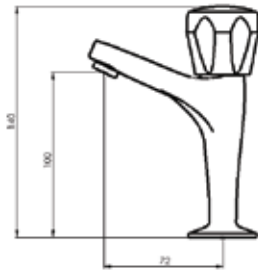

DECK MOUNTED SINK MIXER

Fregadero
Mélangeur évier

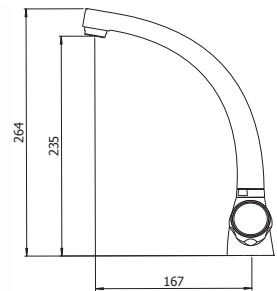

REF.	RRP INC VAT	UOM
922038UK	59.99	PCS



REF.	RRP INC VAT	UOM
922039UK	89.99	PCS



DECK MOUNTED SINK MIXER

Fregadero
Mélangeur évier

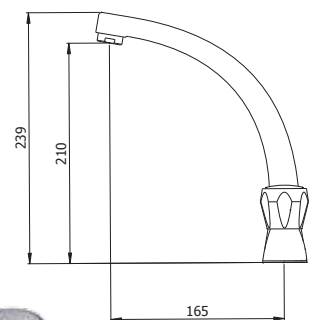

REF.	RRP INC VAT	UOM
922040UK	107.99	PCS



Performa

HIGH NECK SINK TAPS

Fregadero
Mélangeur évier



REF.	RRP INC VAT	UOM
310027UK High Neck Kitchen Tap Hot	83.99	PCS
310037UK High Neck Kitchen Tap Cold	83.99	PCS



HIGH NECK SINK TAPS

Fregadero
Mélangeur évier



REF.	RRP INC VAT	UOM
303007UK High Neck Kitchen Tap Hot	77.99	PCS
303017UK High Neck Kitchen Tap Cold	77.99	PCS



HIGH NECK SINK TAPS

Fregadero
Mélangeur évier

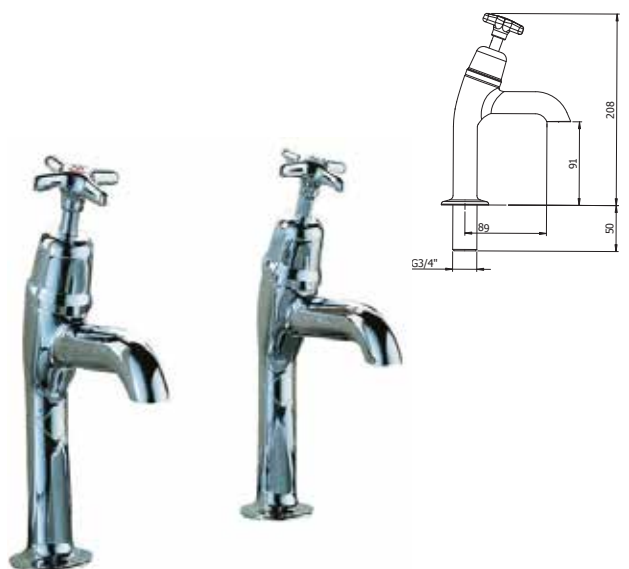

REF.	RRP INC VAT	UOM
307008UK High Neck Kitchen Tap Hot / Cold	83.99	PCS





Technical information and certificates

Información técnica y certificados / Information technique et certificats

Technical information

Información técnica

Information technique

Certificates

Certificados

Certificats





BRASS · LATÓN · LAITON

CAST · FUNDIDO · FONTE



Clever taps use pure alloys, with a minimum impurity quantity. The percentage of lead is really low according to the strictest market requirements. The alloy exempts of pores allows to obtain a high quality polish. Total breaks Absence.

La grifería Clever utiliza aleaciones puras, con una mínima cantidad de impurezas. El porcentaje de plomo es muy bajo en consonancia con las directrices de consumo de agua potable. La aleación exenta de poros logra un pulido de alta calidad. Ausencia total roturas.

La robinetterie Clever est fabriquée à partir d'alliages purs, à très faibles niveaux d'impuretés. Très faibles pourcentage de plomb selon les exigences les plus strictes concernant la consommation d'eau potable. Les alliages sans pores permettent un polissage de haute qualité. Sans aucune fissure.

STAMPING · ESTAMPACIÓN · ESTAMPÉE



High quality European stamping Brass. According rule UE EN 12.164/5. The stamping brass has a high percentage of Cooper (Cu~60%). Very low percentage of Tin (Sn<0,3%), avoids rigidity and possible damages.

Latón europeo estampado de extrusión de primera calidad. Norma UE EN 12.164/5. El latón de estampación contiene un porcentaje muy alto de cobre (Cu~60%). El porcentaje de estaño es muy bajo (Sn<0,3%), evitando la rigidez y posibles daños.

Laiton européen estampé par extrusion, de première qualité. Norme UE-EN 12.164/5. Le laiton estampé contient un fort pourcentage de cuivre (Cu~60%). Très faible pourcentage d'étain (Sn<0,3%), évitant la rigidité et les possible endommagements.

COMPONENTS · COMPONENTES · COMPOSANTS

HOSE BIBS · LATIGUILLAS · FLEXIBLES



Lenght 370 mm according to the rule EN 817. Male nut produced with CW617 (Sn<0,3%). Braided stainless steel AISI 304. Rubber tube EPDM or PEX, avoiding any particles migration. All worldwide certifications. They resist static pressures higher than 130 bars (13MPa).

Longitud de 370 mm, según Norma EN 817. Macho roscado fabricado con CW617 (Sn<0,3%). Trenzado acero Inoxidable AISI 304. Tubo de goma EPDM o PEX, libre de migración de partículas nocivas. Amplia cobertura de certificaciones internacionales. Resisten presiones estáticas de más de 130 bar (13 MPa).

Longeur 370 mm. suivant la norme EN 817. Fabriqué avec CW617 (Sn <0,3%). Tressé en acier inoxydable AISI 304. Tuyau en caoutchouc EPDM o PEX, sans migration de particules nocives. Tous types de certifications mondiales. Supportent des pressions statiques de plus de 130 bar (13 MPa).

AERATORS · AIREADORES · AÉRATEURS



NEOPERL®

Maxim protection against lime residues. Long life. Splashes reduction. Flow straight control and water stream diameter. It produces a straight flow, round, independent to the pressure. Minimum noise level. It allows water save and electricity cost reduction.

Protección máxima contra los residuos de cal. Período de vida de larga duración. Reducción de salpicaduras. Control de rectitud de la corriente y el diámetro del chorro de agua. Producen un flujo recto, redondo, independiente de la presión. Nivel de ruido mínimo. Permiten un ahorro de agua y reducen el coste energético.

Haute protection contre le tartre. Retarde l'apparition d'incrustations calcaires. Longue période de vie. Réduction des éclaboussures. Rectitude du courant et du diamètre indépendamment de la pression. Niveau minimal de bruit. Permettent l'économie d'eau et la réduction du coût énergétique.

CHROMED · CROMADO · CHROMÉ



Extra Chromed, our Chrome process is composed by 44 steps to warranty the corrosion resistance. The surface has to resist the laboratory test which consists of withstanding > 200 hours salt spray test without appearing any defect.

Extra Cromado, proceso de cromado compuesto por 44 pasos que garantizan la resistencia a la corrosión. La superficie debe resistir una prueba de laboratorio que consiste en soportar más de 200 horas de niebla salina sin que se aprecien defectos.

Extra Chrome, procédé de chromage en 44 étapes qui garantissent la résistance à la corrosion. La surface doit être capable de supporter des essais en laboratoire équivalents à 200 heures de brouillard salin, sans endommagements appréciables.



ECCENTRIC NUT · EXCÉNTRICA · RACCORD EXCENTRÉ

The inner design avoids noises from the water circulation. Produced with CW617 (Sn<0.3%) One set installed inside the eccentric nut absorbs the noise when the water flows. Noise reduction around 20 decibels.

El diseño interior evita ruidos procedentes de la circulación del agua. Fabricado con CW617 (Sn<0.3%) Un dispositivo instalado en el interior de la excéntrica absorbe el ruido del agua al pasar por ella. Reduce el ruido alrededor de 20 decibelios.

Sa conception intérieure évite les bruits de la circulation d'eau. Fabriqué avec CW617 (Sn <0,3%). Un dispositif absorbe le bruit de l'eau à son passage par l'excentré. Réduit le bruit de 20 db. approx.



WARRANTY · GARANTÍA CLEVER · GARANTIE

Clever taps have passed the strictest quality controls as all are produced with the best materials and components in order to offer the comfort and durability. Due to reason we offer 5 years guarantee in all our ranges. Delay action taps 3 years. Clever taps carry out the following rules: UNE 19703 / UNE-EN 817 / UNE-EN 816 / UNE-EN 1111, and its quality is guaranteed according to ISO 9001.

Los grifos Clever han pasado estrictos controles de calidad, están fabricados con los mejores materiales y componentes con el fin de ofrecer confort y durabilidad. Es por ello que ofrecemos 5 años de garantía en TODA nuestra gama. Temporizados, 3 años.

La grifería Clever cumple con las indicaciones de las normas: UNE 19703 / UNE-EN 817 / UNE-EN 816 / UNE-EN 1111, y su calidad está garantizada según la norma ISO 9001.

La robinetterie Clever a été soumise aux plus stricts contrôles de qualité et fabriquée à partir des meilleurs matériaux et composants.

Ceci nous permettant d'offrir 5 ans de garantie pour TOUTE la gamme. Temporisés 3 ans.

La robinetterie Clever est soumise aux normes: UNE 19703 / UNE EN 817/ UNE EN 816/ UNE EN 1111 et sa qualité est garantie selon la norme ISO 9001.



gitec
QUORE



Standard

The cartridge uses high advanced sintered ceramic disc with high resistance to wear. All material in contact with water is certified by international norms such as ACS, KTW & W270, Watermark, etc. The sensibility of the handle allows us to get the temperature with exactitude.

Se incorporan cerámicas técnicas sintetizadas de alta precisión con gran resistencia al desgaste. Todos los materiales en contacto con el agua cumplen las normas internacionales sanitarias como ACS, KTW & W270, Watermark, etc. La gran sensibilidad, nos confiere en la maneta un largo desplazamiento lateral entre 34° y 42°. Lo que nos permite obtener la temperatura deseada con exactitud.

Nous avons incorporé des céramiques techniques synthétisées de haute précision, avec une grande résistance à l'usure. Tous les matériaux en contact avec l'eau sont conformes aux normes sanitaires comme l'ACS, la KTW et la W270, Watermark, etc. L'ampleur de déplacement latéral de la manette entre 34° et 42° nous permet d'obtenir la température souhaitée avec la plus grande exactitude.

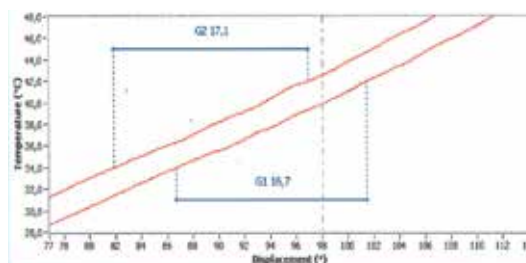

gitec



EcoNature

The EcoNature system consists of an Economizer Cartridge with two positions, assembled and calibrated in the factory, which offers a high level of comfort and it is very easy to use.

The system is based on an end located in the interior of the cartridge, with a smooth gesture provides the volume necessary to guarantee a sufficient water flow for the daily use (saving approximately a 50% in the water consumption), if the maximum volume is desired it is only necessary to rise the handle till the maximum position.

El sistema EcoNature consiste en un cartucho con 2 posiciones, calibrado desde fábrica, el cual ofrece un alto nivel de confort y facilidad de uso. El sistema se basa en un mecanismo situado en el interior del cartucho.

Con un suave gesto suministra el caudal necesario para el uso cotidiano del grifo (ahorrando aproximadamente un 50% en el consumo de agua), si se desea el máximo caudal hay que ejercer una ligera presión en la palanca hacia arriba hasta alcanzar el máximo recorrido de la maneta.

L'EcoNature système consiste à utiliser une cartouche céramique de dernière génération équipée d'un système à 2 positions d'ouverture, assemblé et calibré en usine. Ce système permet de réelles économies d'eau et offre un grand confort d'utilisation.

Son principe de fonctionnement repose sur un dispositif d'arrêt de course du levier, localisé à l'intérieur de la cartouche et qui permet d'obtenir un débit d'eau suffisant pour une utilisation quotidienne (50% d'économie dans la consommation d'eau).

Si le débit maximum est nécessaire, il suffit de lever le levier jusqu'à sa position maximum.



Sistema EcoNature, EcoNature system

ColdOpen

gitec



The Cold open system allows to save hot water thanks to the operation of the handle. In its central position, unlike the rest of the taps, it does not mix hot and cold water, the water is only cold. To obtain hot or warm water, turn the handle to the left.

El sistema Cold open permite ahorrar agua caliente gracias al funcionamiento de la maneta. En su posición central, a diferencia del resto de grifería, no mezcla agua caliente y fría sino que el agua es solo fría. Para obtener agua caliente o templada se debe girar la maneta hacia la izquierda.



Sistema ColdOpen, ColdOpen system

Le système Cold Open permet d'effectuer des économies d'eau chaude grâce au fonctionnement de la manette. Contrairement aux systèmes standard, la manette ouverte en position centrale ne libère que de l'eau froide, sans la mélanger à de l'eau chaude. Pour obtenir de l'eau tiède ou chaude, il faut tourner la manette vers la gauche.

cosedal



Thermostatics

Stability: the temperature remains constant. Comfort: automatically compensates temperature changes. Safety: If the cold water supplied is interrupted, the cartridge will not let hot water to enter and avoid scalding. Accuracy: taps calibrated at 38 ° C.

Exact Temperature. Exactitude: special synthetic cartridge, insensitive to the lime (Ca).

Traceability: STH brand and date marked for a higher control and monitoring.

Estabilidad: la temperatura permanece constante. Confort: compensa automáticamente los cambios de temperatura. Seguridad: si el suministro de agua fría se interrumpe, el cartucho no deja pasar agua caliente de inmediato y evita quemaduras. Precisión: grifos calibrados a 38°C. Temperatura exacta. Exactitud: cartucho sintético especial, insensible a la cal (Ca). Trazabilidad: marcado STH y fecha para un mayor control y seguimiento.

Stabilité: la température reste constante. Confort: les changements de température sont compensés automatiquement. Sécurité: en cas d'interruption du débit d'eau froide, la cartouche ne laisse pas passer l'eau chaude immédiatement, évitant ainsi les brûlures. Précision: les robinets sont calibrés à 38°. Température exacte.

Résistance: cartouche synthétique spéciale, résistante au calcaire (Ca). Traçabilité: marquage STH et datage pour un meilleur contrôle et suivi.

SECURITY · SEGURIDAD · SÉCURITÉ



SAFETY BLOCK

Security system for thermostatic

Tope de seguridad para termostáticos

Système de sécurité pour thermostatiques

This mechanism prevents the water temperature from involuntarily exceeding 38°C. Higher temperatures are only made possible by pressing the appropriate button on the handle. This is an ideal protection device for young children. Flow automatically shuts off if the cold-water supply is interrupted.

Dispositivo que evita temperaturas superiores a 38°C de manera involuntaria. El usuario debe pulsar el botón para conseguir temperaturas superiores. Ideal para la seguridad infantil. Bloqueo automático en el caso de que se interrumpa el suministro de agua fría en la instalación.

Dispositif évitant d'atteindre involontairement des températures supérieures à 38°C. L'utilisateur doit appuyer sur le bouton pour obtenir une température supérieure. Idéal pour la sécurité des enfants. Blocage automatique en cas d'interruption de l'arrivée d'eau froide dans l'installation.

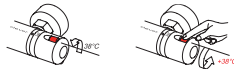

MEDICAL

Elbow activated mixer handle

Accionamiento mediante el codo

Ouverture au coude

The Clever hygienic handle is ideal for situations where a high degree of hygiene is a must. This special handle fits most Clever mixer models and can be easily retrofitted. Please check with our technical department for compatibility.

La maneta gerontológica Clever es ideal para ubicaciones donde los requerimientos higiénicos sean elevados. Además el usuario puede montarla en otros grifos Clever. Consultar compatibilidad con nuestro servicio técnico al cliente.

La manette médicale Clever est tout particulièrement adaptée pour les lieux où les exigences sanitaires sont les plus rigoureuses. Elle peut être installée sur plusieurs modèles de robinetterie Clever. Contacter de notre Département Technique pour vérifier les compatibilités.

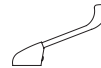

MAXIMUM TEMPERATURE

Restricts temperatures more than 50°C

Bloqueo de temperatura en 50°C

Blocage de température à 50°C

The tap contains a mechanism that restricts temperatures more than 50°C, which is ideal to avoid accidental scalding. Flow automatically shuts off if the cold-water supply is interrupted.

La grifería se bloquea en un máximo de 50°C, el usuario no puede alcanzar temperaturas superiores. Ideal para evitar quemaduras. Bloqueo automático en el caso de que se interrumpa el suministro de agua fría en la instalación.

La température maximale à la sortie des mitigeurs est de 50°C. L'utilisateur ne peut pas obtenir de température plus élevée. Idéal pour éviter les brûlures. Blocage automatique en cas d'interruption de l'arrivée d'eau froide dans l'installation.



ANTIVANDALIC BLOCK

Shuts off the water supply in 60 seconds

Bloqueo suministro de agua a los 60 segundos

Blocage de l'écoulement de l'eau après 60 secondes

Designed for taps installed in public areas. Flow stops automatically after 60 seconds, preventing unnecessary waste. Ideal for places such as airports, hotels, or restaurants.

Tecnología destinada para griferías instaladas en lugares públicos. Consiste en una parada automática a los 60 segundos, evitando gasto de agua innecesario. Perfecto para lugares como aeropuertos, hoteles o restaurantes.

Technologie adaptée à la robinetterie installée dans les lieux publics. Elle permet l'arrêt automatique de l'écoulement d'eau après 60 secondes, évitant ainsi une consommation inutile. Parfait pour des lieux publics comme les aéroports, les hôtels ou les restaurants.

ENVIRONMENT · MEDIO AMBIENTE · ENVIRONNEMENT

**PUBLIC PLACE**

Designed for public places
Diseñado para lugares públicos
Conçu pour les lieux publics

The Clever delay action and sensor taps range is particularly suitable for public areas. These mixers are automatic, vandal-proof and are equipped with an intelligent water-conservation system. The dismantling points of these mixers are cleverly concealed.

Las gamas de temporizados y electrónicos Clever están específicamente diseñados para lugares públicos. Automático, antivandálico, sistema inteligente de ahorro de agua y sistema de desmontaje oculto.

Les séries de robinetteries temporisées et électroniques sont spécialement conçues pour les lieux publics. Mécanisme automatique, anti-vandalisme, système intelligent d'économie d'eau et système de démontage caché.

**ECO SYSTEM**

Limited flow system
Sistema con caudal limitado
Système à débit limité

Environmental flow reduction system from 1l/min to 9l/min. Ideal for shower, basin, bath/ shower and sink mixers.

Sistema ecológico con caudal limitado desde 1l/min hasta 9l/min, en lavabos, duchas, baño-duchas y fregaderos.

Système écologique de réduction de débit dès 1l/min à 9l/min pour la robinetterie de lavabo, douche, bain douche et cuisine.

**AIR ADVANCED**

Air and water mixing device
Mezcla de aire y agua
Mélange air et eau

Our technologically advanced Clever shower heads and handsets are equipped with AIR Advanced technology, which reduces water consumption by at least 30%.

Los rociadores y teléfonos Clever usan la tecnología AIR Advanced. Inyectando aire antes de la salida del agua, se consigue dar volumen a las gotas obteniendo una sensación más suave y confortable en la ducha.

Les pommes de douche et les douchettes Clever sont équipées de la technologie AIR Advanced. L'injection d'air dans l'eau avant sa sortie permet de donner du volume aux gouttes et d'obtenir une sensation de douceur et de confort sans pareille.

**WATER QUALITY**

Purified water supply taps
Grifería para equipos de calidad del agua
Robinetterie pour équipements de qualité de l'eau

Specially designed faucets to deliver drinking water from water purifying equipment.

Grifería especialmente diseñada para conducir agua procedente de equipos de agua tratada.

Robinetterie spécialement conçue pour la conduite de l'eau des équipements de traitement d'eau.

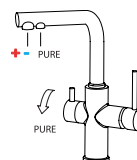



CERAMIC CARTRIDGES · CARTUCHOS CERÁMICOS · CARTOUCHES CÉRAMIQUES

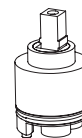

ECONATURE

Cartridge with 2 positions
Cartucho con apertura en 2 posiciones
Cartouche avec 2 positions d'ouverture

The Econature system consists of a 2-position cartridge which is pre-set during production. The special mechanism located inside the cartridge ensures both comfort and ease of use.

El sistema EcoNature consiste en un cartucho con 2 posiciones, calibrado desde fábrica, el cual ofrece un alto nivel de confort y facilidad de uso. El sistema se basa en un mecanismo situado en el interior del cartucho.

Le système EcoNature consiste en une cartouche céramique équipée d'un dispositif à 2 positions d'ouverture, calibrée en usine, qui permet d'effectuer des économies d'eau tout en maintenant un grand confort d'utilisation.



COLD OPEN

Cold Open heat-conserving mixers
Grifería de apertura en frío
Robinetterie avec ouverture sur eau froide

The Cold open system enables energy conservation by suppressing the mixing of hot and cold water while the handle is in a central position. Hot water mixing only occurs when turning the handle to the left-hand side.

El sistema Cold open permite ahorrar agua caliente gracias al funcionamiento de la maneta. En su posición central, a diferencia del resto de grifería, no mezcla agua caliente y fría sino que el agua es solo fría. Para obtener agua caliente o templada se debe girar la maneta hacia la izquierda.

Le système Cold Open permet d'effectuer des économies d'eau chaude grâce au fonctionnement de la manette. Contrairement aux systèmes standard, la manette ouverte en position centrale ne libère que de l'eau froide, sans la mélanger à de l'eau chaude. Pour obtenir de l'eau tiède ou chaude, il faut tourner la manette vers la gauche.



ECO CARTRIDGE

Eco-friendly cartridge with flow restrictor
Cartucho Eco con limitador de caudal
Cartouches Eco avec limiteur de débit

Eco cartridges have been especially designed to limit the flow of water. This cartridge is very efficient in water conservation whilst providing maximum comfort.

Los cartuchos eco han sido diseñados para limitar el caudal. Permite ahorrar agua y proporciona un máximo confort.

Les cartouches Eco ont été conçues pour réduire le débit. Elles permettent d'économiser de l'eau tout en apportant un confort maximal.

TECHNOLOGY · TECNOLOGÍA · TECHNOLOGIE

**WATERFALL**

Waterfall effect
Efecto cascada
Effet cascade

With our Waterfall effect we have introduced a new concept in bathroom mixers in which we achieved a higher level in design whilst simultaneously reproducing the force of nature.

El efecto WATERFALL proporciona un cambio en la concepción de la grifería. El chorro realiza su estética y reproduce la fuerza innata de la naturaleza.

L'effet WATERFALL offre un nouveau concept de la robinetterie traditionnelle. L'écoulement de l'eau en cascade rehausse l'esthétique du robinet en reproduisant la force de la nature.

**PULL-OUT**

Pull-out mixers
Grifería extraíble
Robinetterie extractible

Mixer with pull-out extendable flexible spout.

Grifería de cocina con mango extraíble.

Robinetterie de cuisine avec douchette extractible.

**EASY FIX**

Easy mixer installation tool
Fácil instalación, sin herramientas
Installation facile

This specialised tool enables a fast and easy DIY installation of Clever mixers without the need for additional tools.

Dispositivo que permite el montaje con la mano, sin la necesidad de emplear herramientas.

Dispositif qui permet un montage aisé, sans besoin d'outil spécifique.

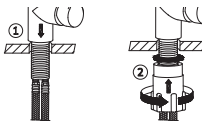
**SUPERFIX**

Under-sink support for kitchen mixers
Anti-movimiento para fregaderos
Renfort anti-mouvements pour éviers

This robust under-sink base provides additional support for Clever kitchen mixers and prevents lateral movement.

Los grifos de cocina Clever disponen de una base que se coloca en la parte inferior de los fregaderos de acero inoxidable, evitando el movimiento del grifo al accionarlo.

Les modèles de cuisine Clever sont équipés d'une base qui se place sous les éviers en acier inoxydable et qui permet une fixation parfaite, évitant le mouvement de la robinetterie lors de son utilisation.

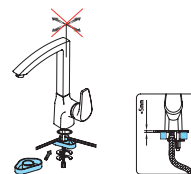

TECHNOLOGY · TECNOLOGÍA · TECHNOLOGIE



CERAMIC CONTROL

Headwork/Diverter cartridge with ceramic disc
Montura/Cartucho inversor con discos cerámicos
Monture/Cartouche inverseur avec disques céramiques

The 99% pure aluminium oxide discs inside these spindle/diverter cartridges last longer and allow 90° and 180° spindle rotation. A special thermal insulator protects against scalding when touching the mixer handle.

Las monturas/cartuchos inversores son de giro 90° y 180° con discos cerámicos, óxido de aluminio de pureza 99%, indegastables. Para disminuir la conducción calorífica se monta un aislante térmico para evitar las quemaduras al accionar el pomo.

Les montures/cartouches inverseur pivotent à 90° et 180° sur disque céramique, oxyde d'aluminium pur 99%, inusable dans le temps. Un isolant thermique est utilisé pour diminuer la conduite de chaleur et éviter les brûlures au contact de la manette.



HIDE DIVERTER

Stylish and fully functional diverter
Inversor estético y funcional
Inverseur esthétique et fonctionnel

This concealed inverter can be activated by pulling out the hose bib, vertically.

Esta tecnología consiste en un inversor no visible que se acciona desplazando el flexible de forma vertical para efectuar el cambio, mezclando estética y funcionalidad.

Ce système consiste en un inverseur invisible qui s'actionne en tirant verticalement sur le flexible de douche, permettant de combiner esthétique et fonctionnalité.



ORIENTABLE

Swivel aerator
Aireador orientable
Aérateur orientable

This aerator allows you to aim the flow of water in any desired direction for additional comfort.

Aireador que permite orientar el chorro de agua hasta la dirección deseada, consiguiendo así un mayor confort.

Aérateur qui permet d'orienter le jet de l'eau à volonté, pour plus de confort.



ANTIVANDALIC

Anti-vandal aerator
Aireador antivandálico
Aérateur anti-vandalisme

This aerator requires a special dismantling tool for additional security.

Para una total seguridad, este aireador requiere herramienta especial para su desmontaje.

Pour une sécurité maximale, cet aérateur requiert un outil spécifique pour son démontage.



CONTACTLESS

Contactless electronic mixers
Grifería electrónica sin contacto
Robinetterie électronique sans contact

Advanced sensor system activates the flow of water without the need for any physical contact.

Sistema de detección para el accionamiento automático de la salida de agua, sin necesidad de tocar con las manos la grifería.

Système de détection automatique permettant d'activer l'écoulement d'eau, sans besoin pour l'utilisateur d'entrer en contact avec la robinetterie.



COLD TOUCH

Anti-scalding design
Grifería anti-quemaduras
Robinetterie anti-brûlures

Our specially designed COLD TOUCH shower and bath-shower mixers prevents the mixer body from becoming too hot thereby protecting young children and senior citizens from scalding.

El diseño especial de nuestras duchas y baño-ducha con COLD TOUCH, permiten que en ningún caso el cuerpo se caliente y queme. Ideal para la seguridad infantil.

La conception particulière des mitigeurs COLD TOUCH permet d'éviter que le corps des mitigeurs de douche et bain-douche ne chauffe et provoque des brûlures. Idéal pour la sécurité des enfants.

TECNOLOGÍA · TECHNOLOGY · TECHNOLOGIE

**MAGNET FIXING**

Sistema magnético de sujeción

*Magnetic attachment system**Système de fixation magnétique*

Para una mayor comodidad, la ducha se sujeta de manera magnética al caño, facilitando el uso del fregadero.

The shower head is magnetically held in place for additional comfort.

Pour plus de commodité la douchette se fixe magnétiquement au bec, ce qui en facilite l'utilisation.

**EURO SLOT HANG**

Packaging con pestaña incluida

*Packaging includes tab**Emballage avec trou européen*

Packaging con pestaña eurocolgadora incluida, perfecta para colgar en expositores o mostradores. Packaging versátil y funcional.

Packaging includes euro hanger which makes it ideal for hanging the product on display stands.

Emballage avec trou européen pour présentation sur broche. Système polyvalent et fonctionnel.

DISEÑO Y CALIDAD · DESIGN & QUALITY · DESIGN ET QUALITÉ

**TOP WARRANTY**

10 years warranty

Garantía calidad 10 años

Garantie qualité 10 ans

Clever mixers are subject to stringent quality control checks which enables us to offer a 10-year guarantee on our entire range.

La grifería Clever se somete a estrictos controles de calidad, es por ello que ofrecemos 10 Años de garantía en todas nuestras gamas.

La robinetterie Clever est soumise à des contrôles qualité très stricts qui nous permettent d'offrir une garantie de 10 ans sur toutes nos gammes.

**TOP WARRANTY**

5 years warranty

Garantía calidad 5 años

Garantie qualité 5 ans

Clever mixers are subject to stringent quality control checks which enables us to offer a 5-year guarantee on our entire range.

La grifería Clever se somete a estrictos controles de calidad, es por ello que ofrecemos 5 Años de garantía en todas nuestras gamas.

La robinetterie Clever est soumise à des contrôles qualité très stricts qui nous permettent d'offrir une garantie de 5 ans sur toutes nos gammes.

**TOP WARRANTY**

3 years warranty

Garantía calidad 3 años

Garantie qualité 3 ans

Clever accessories are subject to stringent quality control checks which enables us to offer a 3-year guarantee on our entire range.

La grifería Clever se somete a estrictos controles de calidad, es por ello que ofrecemos 3 Años de garantía en todos nuestros accesorios.

La robinetterie Clever est soumise à des contrôles qualité très stricts qui nous permettent d'offrir une garantie de 3 ans sur tous nos accessoires.

**PATENTED**

Exclusive patented design

Diseño industrial exclusivo y patentado

Design industriel exclusif et breveté

All our Clever designs are officially registered and patented. This differentiates us from our competitors and fully supports us along our journey into the future. All our patents are exclusive in all EU countries.

Clever patenta sus diseños en la entidad oficial de registros de dibujos y marcas. Es nuestra distinción y el camino hacia el futuro. Las series patentadas son reconocidas para los países de la Unión Europea.

Clever fait breveter ses designs auprès des autorités compétentes pour protéger ses signes distinctifs et avancer vers le futur. Les séries brevetées sont reconnues dans les pays de l'Union Européenne.



APPROVED TAPS

GRIFERIA CERTIFICADA · ROBINETTERIE CERTIFIÉE

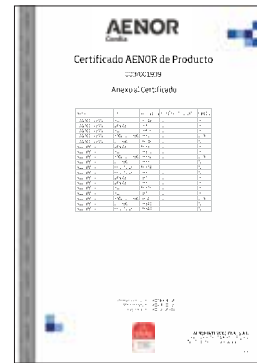
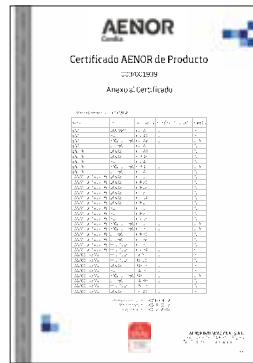

APPROVED TAPS

GRIFERIA CERTIFICADA · ROBINETTERIE CERTIFIÉE

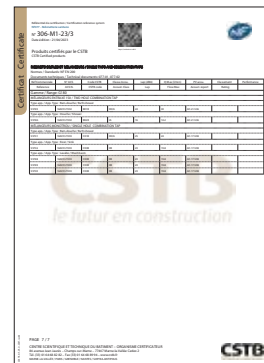
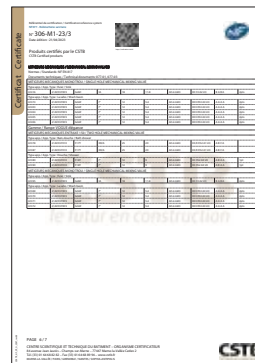
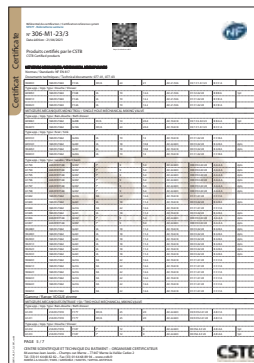
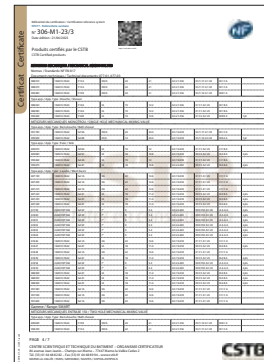
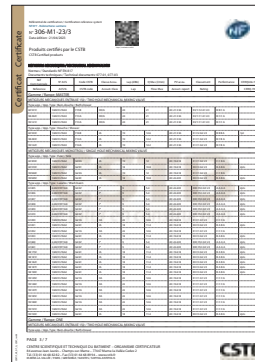



APPROVED TAPS

GRIFERIA CERTIFICADA · ROBINETTERIE CERTIFIÉE



APPROVED TAPS

GRIFERIA CERTIFICADA · ROBINETTERIE CERTIFIÉE

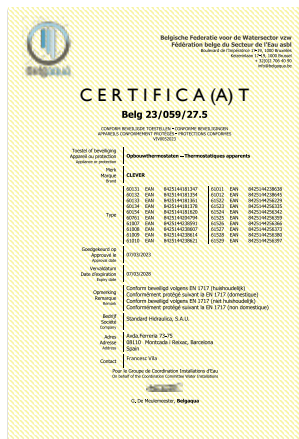
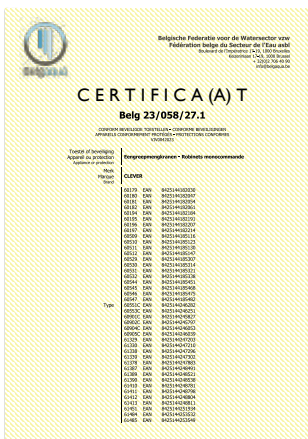



www.clevertaps.co.uk

sth Standard Hidraulica Group

Standard Hidráulica, S.A.U.

Av. La Ferreria 73-75
Pol. Ind. La Ferreria
08110 Montcada i Reixac
Barcelona (Spain)
Tel. +34 93 564 10 94

www.standardhidraulica.com

Standard Hidráulica, S.A.U.

C. Galileo Galilei, 5
28906 Getafe
Madrid (Spain)
Tel. +34 91 692 05 53
Tel. +34 91 643 18 86

www.standardhidraulica.com

STH Westco

Unit C6, William Way
Moss Industrial Estate
St Helens Road, Leigh,
Lancashire - WN7 3PT (UK)
Tel. +44 (0)1942 603351
Fax. +44 (0)1942 607780

www.westco.co.uk

**STH Southern Africa Plumbing
& Heating Equip. (Pty) LTD**

2, Northriding Commercial Park,
Aintree Ave., Northriding
South Africa
Tel. +27 11 462 4504

www.sthza.co.za

**STH Hellas Plumbing &
Heating Equipment,S.A.**

Alexandras str. (Magoula)
Aspropyrgos 19300
Greece
Tel. +302102842684
Fax. +302102840700

www.standardhidraulica.gr